

# THE NEXT STEP IN FRATERNALISM



---

## The Opening, Closing and Conferral Ceremonies of the Moose Legion, the Degree of Service

---

*Revised and certified by the  
International Moose Legion Council  
and approved by the  
Supreme Council*

*In Force and Effect as of  
May 1, 2018*

## TABLE OF CONTENTS

Mission and Vision Statement.....	56
Key to Floor Positions .....	4
Diagram No. 1 .....	5
Steps to Set Up Stations .....	6
Station Set Up Diagram .....	7
Instructions for Preparing Meeting Room .....	8
General Information .....	8
Instructions for Moose Legion Officers.....	9
General Business Meeting Agenda .....	11
Opening Ceremony / Conferral.....	15
Pledge of Allegiance .....	17
Moose Legion Official Visitor Introduction .....	17
Conferral Ceremony.....	19
Informational Meeting Agenda .....	33
Official Visitor's Address.....	33
Endowment Fund / Nine O'Clock Ceremony.....	33
Closing Ceremony.....	35
Line of March for Conferral Entry .....	36
Line of March for Conferral Vacating .....	37
Floor Positions .....	38
Floor Movements .....	39
General Instructions .....	44
Gestures.....	46
Attention and Speaking.....	46
Rules for Competition.....	47
Certificate of Authentication.....	54
Nominating Committee Guidelines .....	55
(Reference Chapter 11 of the Code of Rules)	
Table of Contents .....	58

---

Organization .....	59
Composition .....	59
Meetings .....	59
Responsibilities .....	59
Report to the Membership .....	60
Dissolution .....	60
Campaigning .....	60
Eligibility of Nominees .....	60
Director Qualifications .....	61
Board of Directors .....	61
President .....	62
Election Committee .....	62
Installation of Directors .....	63
Vacancies .....	63
Election of Directors .....	64
Voting .....	64
By Ballot .....	64
By Sign of the Order .....	64
Sample Ballot .....	65
Questions and Answers .....	66
Responsibilities of Elected Directors .....	71
<i>(Code of rules Chapters 12 - 17)</i>	
President .....	71
Vice-President .....	73
Chaplain .....	73
Fraternal Director .....	74
Financial Director .....	75
Conclusion .....	76
Installation of Directors Ceremony .....	77
Board of Directors Meeting Agenda .....	96
Secretary & Assistant Secretaries Meeting Agenda .....	97

## KEY TO FLOOR POSITIONS

1. Sergeant-at-Arms, President, Conferral President, Faith and Chaplain position at the Altar, centered, facing class, and toes within eighteen (18) inches of the Altar edge.
2. Chaplain and Faith station
3. Fraternal Director and Charity station
4. President station
5. Junior Past President and Loyalty station
6. Vice-President and Hope station
7. Sergeant-at-Arms and Orator chair three (3) feet to the right of the President station, with front edge of chair in line with back edge of the President station.
8. Position of all staff members when delivering charges to class unless otherwise instructed. Space extends five (5) feet from edge of Altar nearest President's station and is as wide as standard Altar (32"). Toes must remain within boundaries.
9. Chairs for Orator, Charity and Faith twelve (12) feet from center of Altar. Left edge of Orator's chair in line with the edge of the altar closest to the President's station.
10. Chairs for Conferral President, Loyalty and Hope twelve (12) feet from center of Altar. Right edge of Conferral President's chair in line with the edge of the altar closest to the President's station.
11. Class chairs four (4) feet from Altar and centered. (For competition – two (2) chairs, four (4) feet from Altar and centered and three (3) feet between chairs.)
12. National flag
13. Optional State, Provincial or Moose Legion flag
14. Chaplain position for opening prayer and Sergeant-at-Arms position for balloting on candidates, toes within eighteen (18) inches of Altar and centered, facing side of Altar.
15. Assistant-Sergeant-at-Arms position for balloting on candidates (when applicable), toes within eighteen (18) inches of Altar and centered, facing side of Altar.
16. Conferral President moves to a position prior to vacating that matches that of the Orator.  
(Vacating position of Orator and President are to mirror each other.)
17. Faith position prior to vacating
18. Charity position prior to vacating
19. Orator moves straight forward from his chair to a position where his feet are the same distance forward or back of the front edge of the station, matching team members at their stations, forward or back from the front edge.  
(Vacating position of Orator and President are to mirror each other.)
20. Loyalty position prior to vacating
21. Hope position prior to vacating

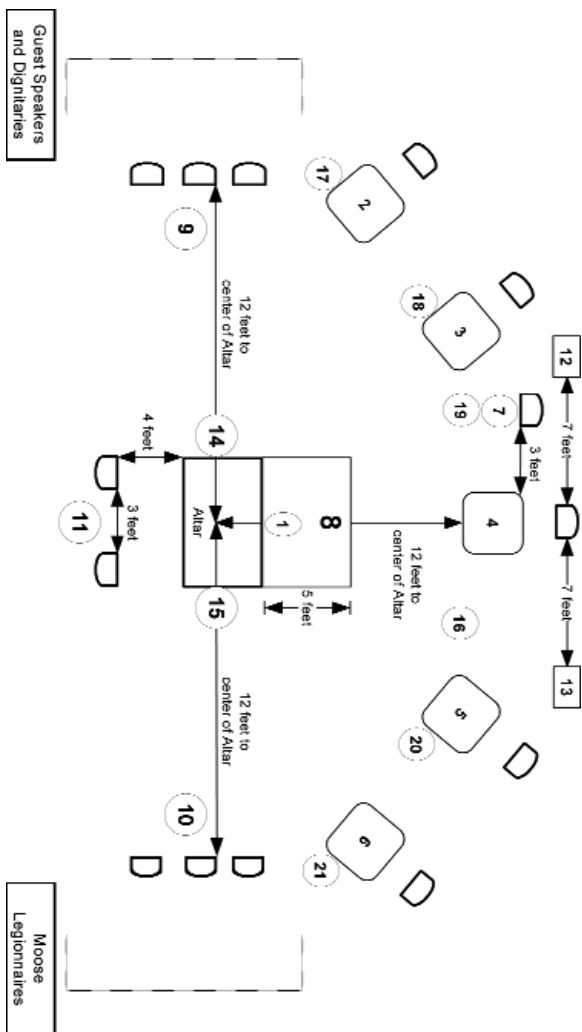
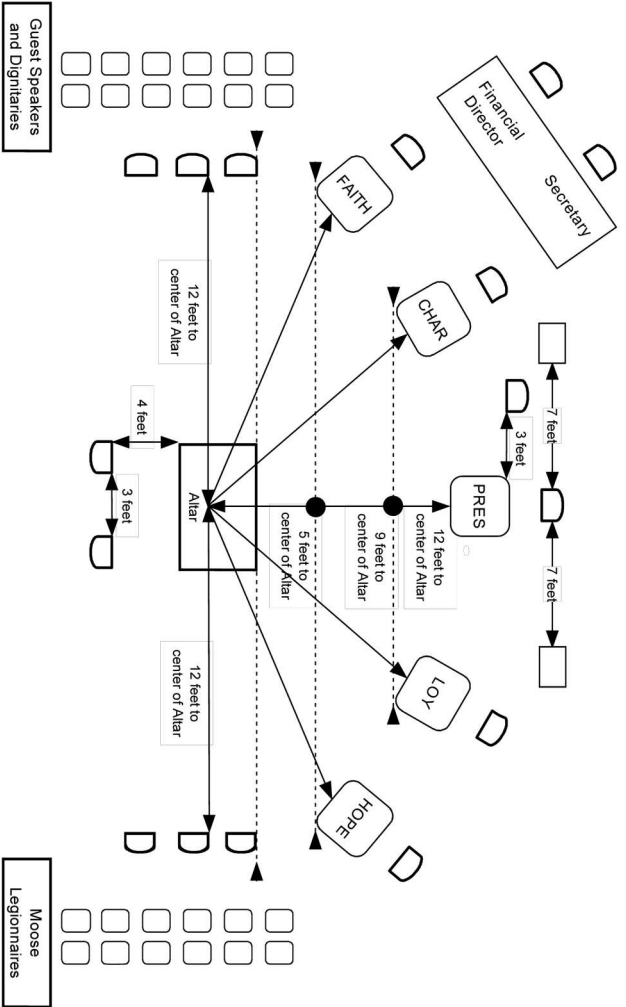

Diagram No. 1

## **STEPS FOR SETTING UP STATIONS FOR A MOOSE LEGION MEETING OR CONFERRAL**

1. After Altar is set, measure 12 feet from the center of the Altar to the center of the front edge of the President's station.
2. Along the line between the Altar and the President's station, mark a point 5 feet from the center of the Altar, and another point 9 feet from the center of the Altar (shown by dots above).
3. Position the stations for Charity and Loyalty so that the outside corners of the station are on an imaginary line through the mark at 9 feet (shown by dotted line above). Do the same thing with the stations for Faith and Hope using an imaginary line through the mark at 5 feet.
4. Once corners are set, measure 12 feet from the center of the Altar to the center of the front edge of each station. If necessary to get the proper measurement, slide the station toward or away from the Altar (keeping the corner on the imaginary line), and pivot the station until proper distance is achieved.



## **INSTRUCTIONS FOR PREPARING MEETING ROOM**

Prior to the Moose Legion meeting, the Sergeant-at-Arms will assure the meeting room is in readiness. Stations, Altar, chairs, tables, and flag(s) should be in their proper positions (per Diagram 1). The Sergeant-at-Arms will also properly place a gavel and prepare the Altar and stations. The correct station cover should be on each station, and the Altar should be properly draped. A closed Bible and folded Charter shall be placed on the Altar.

### **GENERAL INFORMATION**

Thirty (30) minutes prior to the Conferral, the candidates are asked to assemble in the ante room. The President and Secretary will introduce themselves and briefly outline procedures and information to assist the candidates. The Secretary can save time during the meeting by completing a roll call of candidates at this time.

The Assistant Sergeant-at-Arms shall take positions at the principle entrance to the meeting room, and all other entrances shall be closed. Membership cards and candidates' credentials, as provided by the Secretary, shall be examined upon entry. Other than candidates, Moose Legion members that cannot produce a membership card with current dates for Lodge and Moose Legion dues are not to be admitted to any Moose Legion Conferral. Any questions should be reported to the President. Moose Legionnaires should be directed to seats around the room, and candidates shall be seated in prescribed chairs. Only Moose Legion members in active status are allowed to attend Business meetings of the Moose Legion.

All Meetings and/or Conferrals can be performed in any sequence to achieve a harmonious flow, but each meeting agenda/conferral shall be performed in it's entirety.



---

## INSTRUCTIONS FOR MOOSE LEGION OFFICERS

**OPENING** – Directors and appointed officers shall be in place prior to the appointed hour, and the President shall call the meeting to order at the scheduled hour if a quorum of seven (7) active status Moose Legionnaires is present, even though no other member of the Board of Directors is in attendance. The President shall fill vacancies by pro-tem appointments. If the President is absent, the Vice-President shall preside.

**MEMORIZATION** — It is recommended that, all elected Directors commit their parts in the Opening and Closing Ceremonies to memory. The Moose Legion should be opened and closed, and the Conferral Ceremony performed as indicated.

**MEETING** — The President may be seated during the business session of the Moose Legion meeting or when so instructed. He should stand when speaking or being addressed. All remarks should be directed to the President, unless permission has been given to address another Moose Legionnaire.

**ADDRESSING DIRECTORS** — The Board of Directors and appointed officers are addressed by their titles followed by their first names (i.e. “President Mike”, “Sergeant-at-Arms Dave”). All other members of the Moose Legion are addressed as “Moose Legionnaire (first name)”. A member desiring the floor will rise, wait to be recognized by the President, and address him as “President (first name)”. The President will address the member by saying “Moose Legionnaire (first name)”, whereupon the member will proceed. When the President calls for a report or gives individual instructions, the member being addressed will rise and proceed.

**ORDER** — When, in the opinion of the President, a Moose

Legionnaire is guilty of disorderly conduct, he shall be denied the floor and may be reprimanded, fined or both (see Section 12.1 of the Moose Legion Code of Rules).

**ADJOURNMENT** — The presiding officer will accept no motion from the floor to adjourn. The Closing Ceremony must be completed in full.

**PARAPHERNALIA** — Altar cloth and station covers, Directors' and officers' emblems, and all other official Moose Legion paraphernalia must be obtained from Moose International. The Sergeant-at-Arms is responsible for making sure all paraphernalia is properly stored after each meeting.

**VISITING MOOSE LEGIONNAIRES** — The President will assure himself that all visiting members of the Degree of Service are in active status with their respective Lodge and Moose Legion, and are eligible to be present at the meeting.

**ATTIRE AND MEDALLIONS** - Moose Legion Directors and appointed officers should be dressed in appropriate attire for all meetings of the Moose Legion, and shall wear their official emblems during celebrations and meetings of the Moose Legion.

Appropriate attire is defined as the official regalia worn in its entirety (per Section 27.1 of the Moose Legion Code of Rules) or the Moose Legion vest.

Directors' and appointed officers' emblems shall not be worn outside the official Moose Legion Celebrations or meetings at any time.

**BALLOTING**-Balloting on candidates shall be conducted in an orderly manner. The ballot box (cradle or other designated container) shall be placed on the Altar. Should it be necessary to move the Bible and Charter to accommodate the ballot box, the Bible shall be closed and the Charter

folded. The items are re-opened and returned to the center of the Altar once balloting is completed.

The Sergeant-at-Arms shall stand in Position 14 (and the Assistant Sergeant-at Arms in Position 15 when applicable) until the President declares the balloting has been completed. To conserve time when balloting, especially when there is a large attendance, the President shall instruct a double line to be formed, approaching the Altar from both sides.

The President shall, at all times, control the overall conduct of the meeting. He ensures that all activities are moral and not personally degrading or offensive to any individual in attendance. The President is likewise responsible for making sure that excessive or repeated fining is not allowed. Candidates may not be involved in any activities related to balloting, unless they have been informed in advance and have granted individual permission. No alcoholic beverages or smoking shall be allowed in the meeting room during a Board of Directors' meeting, general membership meeting, Directors and Assistant Secretaries Meeting or any official ceremony of the Moose Legion.

## **General Business Meeting Agenda**

*(Business Meetings do not require Instructions For Preparing Meeting Room to be performed)*

**PRESIDENT:** *(Gives one rap)* The Business Session of \_\_\_\_\_ *(name)* \_\_\_\_\_ Moose Legion No. \_\_\_\_\_ will come to order.

**PRESIDENT:** Sergeant-at-Arms *(first name only)*, *(Pauses as Sergeant-at-Arms rises)* are all Moose Legionnaires present entitled to remain?

**SERGEANT-AT-ARMS:** They are President (*first name*)  
We have a total of \_\_\_\_ Moose Legionnaires present.  
(*This count is to ascertain that a quorum is present*)

**PRESIDENT:** Moose Legionnaires, I welcome you to this meeting of the Degree of Service.

Secretary (*first name*) will call the roll of directors, appointed officers and committee chairmen.

(*The Sergeant-at Arms rises. As the Secretary calls the roll, the Sergeant-at-Arms responds, "Present" or "Absent" after each name. Each director, appointed officer and committee chairman stands as his name is called and remains standing until seated by the President. If someone is called "Absent", the President will make a pro-tem appointment.*)

**SECRETARY:** President (*first name*), the roll has been called.

- 1. Election of Directors (Conducted at Annual Celebration)**
- 2. Reading of Minutes from Previous Membership Meeting**

**PRESIDENT:** (*Gives one rap and pauses until all are seated*):

We will now call on our Secretary (*name*) to present the minutes of our previous membership meeting for approval.

(*The Secretary reads if necessary the minutes or announces they were previously distributed for review by the members*)

**PRESIDENT:** May I have a motion and second to approve the minutes of our previous membership meeting? (recognize members from floor on motion & second – Secretary records names) Are there any questions? (if so address or ask Secretary, etc. to address as may be

appropriate) (after any questions) We have a motion and second on the floor to approve the minutes. All in favor signify by the usual voting sign of the Order (pause for vote and count) – All opposed by the same sign. – The vote is favorable (or not – if not try to resolve by asking for a motion to approve all but \_\_\_\_\_ - the item that may be in question).

### **3. *Reading of Minutes from Previous Board of Directors' Meeting(s)***

*(Note: Each set of minutes that is read requires a proper motion, a second and a favorable vote in order to be accepted.)*

**PRESIDENT:** We will now call on our Secretary (name) to present the minutes of our Board of Directors meeting for approval.

*(The Secretary reads if necessary the minutes or announces they were previously distributed for review by the members)*

**PRESIDENT:** May I have a motion and second to approve the minutes of the Board of Directors meeting? (recognize members from floor on motion & second – Secretary records names) Are there any questions? (if so address or ask Secretary, etc. to address as may be appropriate) (after any questions)

We have a motion and second on the floor to approve the minutes. All in favor signify by a show of hands (pause for vote and count) – All opposed by the same sign. – The vote is favorable (or not) (If not try to resolve by asking for a motion to approve all but \_\_\_\_\_ - the item that may be in question)

### **4. *Report of Standing and Special Committees***

- a. Membership Building – Chaired by Vice President
- b. Publicity and Member Relations – Chaired by Chaplin
- c. Financial / Fundraising Report – Chaired by Financial Director

- d. Fraternal Operations – Chaired by Fraternal Director
- e. Membership Retention – Chaired by Jr. Past President
- f. Auditing- Chaired by active status Moose Legionnaire
- g. Special Committees- Chair appointed by President

(Note: Each report that is read requires a proper motion, a second and a favorable vote in order to be accepted.)

**PRESIDENT:** May I have a motion and second to approve the Report as read? (Recognize members from the floor on motion & second – Secretary records names) Are there any questions? (If so address or ask Secretary, etc. to address as may be appropriate) (vote)

**PRESIDENT:** All in favor signify by the usual voting sign of the order (pause for vote and count), all opposed by the same sign. The vote is favorable (or unfavorable).

#### **5. *Old Business***

**President:** Anything to be considered under Old Business?

#### **6. *New Business***

**President:** Anything to be considered under New Business for referral to the Board of Directors?

#### **7. *Results of Election of Directors (Conducted at Annual Celebration)***

#### **8. *Closing***

**PRESIDENT:** Thank you for attending this business session. Our Informational meeting and conferral of new members is scheduled to start at \_\_\_\_\_. We would appreciate seeing all of you then. This Business session is now closed until called to meet again by the Board of Directors at our next celebration.

## OPENING CEREMONY / CONFERRAL

*(Prior to start of meeting ,All Moose Legionnaires, A Lady accompanying a Moose Legionnaire, All Candidates, Family Members of a Candidate, Invited Guests and Official Visitor will enter the Lodge Hall and be seated.)*

**PRESIDENT:** *(Gives one rap)* \_\_\_\_\_ *(name)* \_\_\_\_\_ Moose Legion No. \_\_\_\_\_ will come to order. The Directors and appointed officers will assume their respective stations. Candidates will remain seated until otherwise instructed.

**PRESIDENT:** Assistant Sergeant-at-Arms *(first name)* will admit those entitled to enter for the Conferral Ceremony.

**PRESIDENT:** *Sergeant-at-Arms (first name only), (Pauses as Sergeant-at-Arms rises)* are all Moose Legionnaires present entitled to remain?

**SERGEANT-AT-ARMS:** They are President *(first name)*

**PRESIDENT:** Moose Legionnaires (ladies and candidates), I welcome you to this Conferral of the Degree of Service.

Secretary *(first name)* will call the roll of Directors, Appointed Officers, Committee Chairmen, Lodge Moose Legion Committee Chairmen and Assistant Secretaries.

*(The Sergeant-at Arms rises. As the Secretary calls the roll, the Sergeant-at-Arms responds, "Present" or "Absent" after each name. Each director, appointed officer and committee chairman stands as his name is called and remains standing until seated by the President. If someone is called "Absent", the President will make a pro-tem appointment.)*

**SECRETARY:** President *(first name)*, the roll has been called.

**PRESIDENT;** *(Gives one rap and pauses until all are seated):* Sergeant-at-Arms *(first name)*, please prepare the Altar.

*(The Sergeant-at-Arms rises and proceeds to Position 1. He raises and unfolds the Charter as he speaks and places the open Charter in the center of the Altar. He then raises and opens the Bible as he speaks and places the open Bible on top of the Charter. The Bible and Charter are placed facing Position 1.)*

**SERGEANT-AT-ARMS:** The Moose Legion Charter is our link to those who first believed in the principles and purposes of the Degree of Service. We place upon the Charter an open Bible as a symbol of our faith in a Supreme Being.

*(Sergeant-at-Arms returns to his chair and remains standing.)*

**PRESIDENT:** Candidates (& Ladies) will remain seated. *(Gives two raps)* Moose Legionnaires please rise.

*(The President and Chaplain proceed in unison directly to the Altar – the President to Position 1 and the Chaplain to Position 14.)*

**PRESIDENT** *(From Position 1):* Please repeat after me.

*(Pause)* I promise to aid and protect – Mooseheart and Moosehaven – to the full extent of my ability. – I will remain loyal to their ideals – and noble purposes. – I will earnestly strive – to do some good thing – for someone each day.

**PRESIDENT** *(From Position 1):* Moose Legionnaires, we are privileged and honored to assemble as members of the Degree of Service. Our mission is to have fun while providing greater service to the Moose Fraternity. May we set an example of fraternal service that is worthy of emulation by all our Brothers. *(Pause)* The candidates *(and Ladies and Invited Guest)* will please rise. *(Pauses as candidates, Ladies and Invited Guest rise)* The Chaplain will lead us in prayer.

**CHAPLAIN** *(From Position 14):* Let us fold our arms



*(Pause)* and bow our heads. *(Pause)* Our heavenly Father, we are gathered to provide greater service to our Mooseheart children and Moosehaven seniors. Bless those who have the responsibility of caring for the residents on both campuses. Let us always extend the hand of fellowship and brotherhood to our fellow members and their families, and inspire us to seek only the good that exists in others. In these things, we ask Thy divine guidance. Amen.

*(The President and Chaplain return to their respective stations.)*

**PRESIDENT** *(In the USA)*: Everyone please face the flag of our country, place your right hand over your heart, and join with me in the Pledge of Allegiance. All active military personnel and veterans may salute the flag if they prefer. *(Pause)*

### **PLEDGE OF ALLEGIANCE**

“I pledge allegiance to the flag of the United States of America and to the Republic for which it stands, one nation under God, indivisible, with liberty and justice for all.”

**PRESIDENT**: *(in Canada)* Everyone, please face and salute our flag. You will join me in singing “O Canada.”

**PRESIDENT**: *(Gives one rap)*: Everyone will be seated.

### **INTRODUCTION OF MOOSE LEGION OFFICIAL VISITOR**

**PRESIDENT**: At this time, we would like to welcome *(Title) (name)* who is visiting with us.

*(The Official Visitor is only introduced at this time. He will address the meeting following Good of the Moose Legion.)*

#### ***1. Roll Call of Lodges and Moose Legionnaires***

**PRESIDENT**: Secretary *(first name)*, please proceed with

the roll call of lodges and Moose Legionnaires. Candidates (& Ladies) present for conferral should stand when their lodge is called.

*(The Secretary proceeds with the roll call and notes the number of Moose Legionnaires, Candidates (& Ladies) present from each lodge. Multiple members should only stand once and be counted for one lodge.)*

**SECRETARY:** President (first name), the roll has been called.

### ***2. Applications for Membership***

**PRESIDENT:** Secretary (first name), do we have any new applications for membership or any applications for re-enrollment?

**SECRETARY:** We do (*do not*), President (first name). *(If there are no applications for membership, proceed to Item #4. If there are no candidates to be conferred, proceed to Item #6.)*

**PRESIDENT:** Please read the names of the applicants and their sponsors.

### ***3. Report of Committee on Applications***

**PRESIDENT:** Secretary (first name), please give the report from the committee on applications.

**SECRETARY:** President (first name), the report from the committee on applications is favorable.

### ***4. Balloting on Candidates***

**PRESIDENT:** Sergeant-at-Arms (first name), please prepare the ballot. *(Pause)* In the Moose Legion, currency is used to vote. Paper elects; coins reject. The amount derived from this ballot is for the benefit of our Mooseheart children and Moosehaven seniors. Each

Moose Legionnaire will approach the Altar, cast a ballot, then return to his place and be seated. (*Gives two raps*)

**PRESIDENT** (*After balloting is completed*): Sergeant-at-Arms (*first name*), please present the ballot to Junior Past President (*first name*) for inspection.

*(The Sergeant-at-Arms presents the ballot to the Junior Past President for his inspection, and then proceeds with the ballot box to the President's station.)*

**PRESIDENT** (*After the Junior Past President has completed inspection*): Junior Past President (*first name*), how do you find the ballot?

**JUNIOR PAST PRESIDENT**: President (*first name*), I find the ballot favorable (*unfavorable*).

**PRESIDENT**: I confirm the report of the Junior Past President and declare these applicants duly elected (*rejected*).

*(If the ballot is unfavorable, the President shall call upon the Moose Legionnaires to ballot again. Only two ballots are permitted. Candidates are not permitted to vote on themselves or donate money. When the President has concluded the balloting, the Sergeant-at-Arms shall deliver the ballot to the Financial Director.)*

**PRESIDENT**: (*If the Bible and Charter were closed for Ballot*) Sergeant-at-Arms (*first name*), please prepare the Altar.

### **5. Conferral Ceremony**

*(Conferral Staff takes their places in Positions 9 & 10.)*

**PRESIDENT**: Moose Legionnaires, candidates and guests; during the Conferral Ceremony you are asked to remain quiet, refrain from drinking and smoking, and make sure that all electronic devices are turned off. Now,

please give your full attention to our proud record of service to the Moose Fraternity.

*(Pause) The Conferral Ceremony of the Moose Legion will now begin. (On the word "begin", the directors and appointed officers vacate their respective stations as the Conferral Staff rises from their chairs in Positions 9 & 10.)*

**CONFERRAL PRESIDENT:** *(Gives one rap and gestures to seat staff; staff members, with the exception of the President, seat themselves; Conferral President begins charge in Position 4):*

My Brothers, it is an honor and privilege to welcome you to the Moose Legion, and to this conferral of the Degree of Service.

*(The Conferral President continues his charge while moving to Position 8.)*

An invitation to take this next step in fraternalism was extended to you because you met the requirements necessary for elevation to this Degree, and because you have demonstrated your dedication to three great principles of the Loyal Order of Moose: Purity of mind, body and heart; Aid to our fellow members and our fellow man; and Progress that ensures fraternal growth and prosperity for years to come.

Congratulations on attaining this level of fraternal achievement. Through your loyalty and dedication to our cause, you have risen above others and have established yourself as a most important member of your Lodge. Because of this, you will now advance into the higher degrees of our Order.

When you applied for membership in the Loyal Order of Moose, you signed an obligation promising to give of your

energy and substance in support of Mooseheart and Moosehaven, and to increase the strength of our Order by proposing qualified individuals for membership. Your presence here today indicates that you have fulfilled that initial obligation. As you become a proud Moose Legionnaire, you will take your rightful place in the history of the Moose Legion and its many accomplishments. In return, we ask for a lifetime commitment to the noble endeavor of doing some good thing for someone each day.

Listen carefully as the Orator relates the mission of the Moose fraternity.

*(When his charge is completed, the - Conferral President turns left, steps off with his left foot, returns to Position 4 with station on his left, turns left and is seated.)*

*(As the Conferral President breaks Position 8, the Orator rises, steps off on his left foot and advances to Position 8. He does not begin his charge until the Conferral President is seated.)*

**ORATOR:** The Moose is an international organization of men and women, dedicated to caring for young and old, bringing communities closer together and celebrating life. This statement not only describes the mission of our Order, it is the very essence of who we are, what we believe and what we do.

Our caring for kids begins at Mooseheart, a one thousand acre community located 40 miles west of Chicago. This magnificent educational and residential facility for children in need is one of the crowning achievements of the Moose fraternity. It is a complete community, with modern family style homes; its own school; health care and recreational facilities; and the magnificent House of God, where our foster sons and daughters worship in the faith in which they were raised. Throughout Mooseheart's

existence, students have excelled in our athletic, musical and vocational programs, and countless numbers of our graduates have become leaders in all walks of life.

Caring for senior members of our Order begins at Moosehaven, our City of Contentment, located on the banks of the St. Johns River in Orange Park, Florida. Moosehaven is a state-of-the art retirement community where our senior members and their spouses live together free from the care and burden that age sometimes brings.

Moosehaven is not just a retirement community; it is home, a home of comfort, convenience and security with residents who are active and independent. The atmosphere that we have created is adding life to their years and years to their lives.

One of the cornerstones of our fraternal operation is Community Service. It breathes life into our motto of 'doing some good thing for someone each day'. Our fraternal units contribute tens of millions of dollars in community service annually. We strive to reach even greater heights in our charitable efforts, which will strengthen our reputation of caring for those in need. We believe that the greater our deeds, the stronger our fraternity.

When we talk about celebrating life, we are referring to much more than social activities. You will form lifelong friendships with Moose Legionnaires throughout the fraternity, creating lasting memories and treasuring them forever. We celebrate life by remembering our past, enjoying our present and ensuring our future.

Moose Legionnaires give added force and meaning to the celebration of life by advancing the principles of Faith, Hope and Charity; faith in our cause, hope for continued success and an increased obligation to charity that comes with advancement within our ranks.

---

Hear now the inspiring message of Faith.

*(When his charge is completed, the Orator turns right, steps off with his right foot, returns to Position 7, turns left and is seated.)*

*(As the Orator breaks Position 8, Faith rises, exits Position 2 with station on his left and proceeds to Position 8 to deliver his charge. He does not begin his charge until the Orator is seated.)*

**FAITH:** The emblem of our Order is unique in all the animal kingdom. The moose is strong and majestic. He takes only what he needs, nothing more. By nature, he is a protector and defender. Forming a defending circle with his brethren in their prime, he becomes a guardian for his family, a family that includes every member of the herd, especially the very young and very old; those who are most vulnerable. The strength created by this action illustrates our belief in the old saying ‘one for all and all for one’.

New members are vital to the continued strength of the Loyal Order of Moose and the Moose Legion. You are within our Defending Circle. As a component of this Circle, you are counted upon to look after other members and assist those in need. The form of the Circle communicates the message that we stand ready to help one another. At meetings of our Lodge, whenever a member has gone to his final reward, we break the Defending Circle to acknowledge that he is absent and will forever be missed.

We have faith in our members and believe strongly that a burden heavy to one is borne lightly by many. The Legend of the Locked Horns is a long-standing parable about two moose in deadly combat, fighting one another rather than fighting together for the common good. In that fight, the horns of the two moose lock together. Neither can break free. Both are lost forever, and the herd is diminished. This

story demonstrates that we must work together in a harmonious way to increase the achievements of our Order and the communities we are privileged to serve.

Here stands the reality of the mission of James J Davis, our first Director General and the creator of the Moose Legion. His vision was to band together the men and women of the Moose to serve first the entire family, and then to reach out to those outside our Defending Circle through unselfish acts of kindness. This great vision continues today!

Now hear the message of Hope.

*(When his charge is completed, Faith turns right, steps off with his right foot, returns to Position 2 with station on his left, turns left and is seated.)*

*(As Faith breaks Position 8, Hope rises, exits Position 6 with station on his left and proceeds to Position 8 to deliver his charge. He does not begin his charge until Faith is seated.)*

**HOPE:** The year 1913 was momentous in the history of our fraternity. In addition to the formation of the Women of the Moose, we saw the opening and dedication of our Child City, Mooseheart. This community was a most ambitious undertaking for our young organization, and it presented a new urgency to provide an avenue for those members who wished to make even greater contributions. As a result, the Moose Legion was born that same year.

Initially, the sole purpose of the Moose Legion was to create a one million dollar endowment fund that would meet the financial needs of the fledgling Mooseheart campus. As the fraternity continued to grow, so too did the role of the Moose Legion. When our fraternal leaders sought to establish a retirement community for our senior members, it was the Moose Legion that helped to finance the purchase and development of the land that would



become our City of Contentment, Moosehaven. Today, our campuses are filled with structures and landmarks that have been constructed thanks to the generosity of Moose Legionnaires throughout the fraternity.

In addition, the Moose Legion provides financial support to maintain two important resources. Since 1959, our Mooseheart children have enjoyed year-round recreation at Camp Ross, a one hundred fifty-acre facility located 60 miles west of Mooseheart. Funds from each member's annual dues are designated for the operation of Camp Ross, and are used to maintain and expand the facility. This rolling, beautifully wooded retreat, combined with modern amenities and a secure location, has given our students a getaway that they continue to enjoy throughout the year.

Members of the Moose Legion also ensure top-notch medical care for our Moosehaven residents by maintaining the Moosehaven Seniors' Medical Fund. As with Camp Ross, a portion of each Moose Legionnaire's dues is used exclusively to help defray the increasing costs of medical services for our seniors. By assuming these added responsibilities, it is easy to see why the Moose Legion is identified as the "Degree of Service".

Gentlemen, we are the men who make things happen, the men who get things done! Our instant response, whenever an essential need has been presented at Mooseheart or Moosehaven, has become legendary within this Order, and indeed expected as the norm. We are extremely proud that we have earned this reputation and we have no doubt that you will do your part in helping to maintain it. You have heard the messages of Faith and Hope. Listen further as you are enlightened with words from Charity.

*(When his charge is completed, Hope turns left, steps off with his left foot, returns to Position 6 with station on his left, turns left and is seated.) (As Hope breaks Position 8,*

*Charity rises, exits Position 3 with station on his left and proceeds to Position 8 to deliver his charge. He does not begin his charge until Hope is seated.)*

**CHARITY:** When we were children, we learned about receiving. We received gifts on special occasions and it brought us joy. As we grew older, we began to realize that it is more rewarding to give than to receive. Your advancement into the Moose Legion provides even more opportunities to experience the joy of giving, the greatest joy of all.

In the spirit of charity, Moose Legionnaires initiated a “Penny Fund” in 1913 to address any emergency that may befall our beloved Child City. Since that time, the “Penny Fund” has evolved into the Mooseheart/Moosehaven Endowment Fund, and tens of millions of dollars have been contributed by our members to ensure significant financial assistance for both our Child City and our City of Contentment. Our members continue to give today, and the interest earned on our investment provides support to the essential needs of both communities.

In addition, our fraternal units support projects that serve local communities. Wherever and whatever the need, Moose Legionnaires are there, and they are actively involved. It is not just a matter of giving of your money; it is also giving of your time. Membership in the Moose Legion will provide you with proof that commitment and service go hand in hand with fun and fellowship. By providing outstanding service to our communities, we draw others to our Order, more for what we do than for what we say.

Your elevation into the Moose Legion unlocks the door to further advancement in our Order, and provides you with the pride of knowing that you do, in fact, make a difference in the lives of others.

Prepare now to receive your obligation of membership in the Moose Legion and acknowledge your commitment as a Moose Legionnaire.

*(When his charge is completed, Charity turns right, steps off with his right foot, returns to Position 3 with station on his left, turns left and is seated.)*

*(As Charity breaks Position 8, the Conferral President rises, exits Position 4 with station on his left and proceeds to Position 1 to deliver the obligation. He does not begin speaking until Charity is seated.)*

**CONFERRAL PRESIDENT:** My Brothers, you have responded to a call to let your light shine brighter than ever before, in service to those in need. Please stand **(Pause)** and join me in reciting the Oath of Allegiance to the Moose Legion.

*(The - Conferral President gestures the class and staff to rise as the words "Please stand " are spoken. His attention shall be on the class.)*

Please raise your right hand, place your left hand over your heart, and repeat after me, using your name where I use mine:

*(The - Conferral President will demonstrate his instructions for raising the right hand and placing the left hand over the heart. Movements will be performed after each instruction is given. Movements by staff members shall be done in unison with the Conferral President. Staff members shall repeat the obligation along with the class.)*

**I \_\_\_\_\_ - in the presence of those here assembled - do solemnly promise - that I will faithfully - and to the best of my ability - exemplify the principles - and precepts of the Moose Legion. - I will be steadfast in my commitment - and tireless in my**

**efforts - in support of the Degree of Service. - To all of this – I pledge my sacred oath - so help me God.**

You may lower your hands. (*The - Conferral President lowers his hands after saying the words “You may lower your hands”. Staff members lower their hands in unison with the - Conferral President.*)

It is with honor and humility that I confer upon you the title of Moose Legionnaire. May you wear your regalia proudly as a symbol of the recognition that has been provided you in return for your continued loyalty and dedication.

You may be seated. (**Pause**) Pay heed to the lessons of Loyalty and remember them from this day forth.

(*The - Conferral President gestures the class and staff to be seated as the words “You may be seated” are spoken.*)

(*When his charge is completed, the Conferral President turns left, steps off with his left foot, returns to Position 4 with station on his left, turns left and is seated.*)

(*As the - Conferral President breaks Position 8, Loyalty rises, exits Position 5 with station on his left and proceeds to Position 8 to deliver his charge. He does not begin his charge until the Conferral President is seated.*)

**LOYALTY:** Moose Legionnaires, we congratulate you on the honor this day bestowed upon you. You have taken the next step in fraternalism, and with that step comes expectations. You will be held to a higher standard, and your words and actions will carry greater volume and meaning. You have been asked to increase your service to children and senior members by contributing more of your time, energy and substance to the causes we represent. Since our inception, thousands of Moose Legionnaires have proudly stepped forward and accepted the challenges

that have been placed before them, and they have always come through.

Moose Legionnaires are leaders. They are the fuel that feeds the fire; the engine that drives the car; but most of all, they are loyal fraternalists who roll up their sleeves and make things happen. They recognize that there are no greater responsibilities in this fraternity than strengthening its membership and providing financial support to Mooseheart and Moosehaven.

In addition to loyalty, another defining trait of a Moose Legionnaire is pride. We are proud of our accomplishments. We show our pride by wearing the official regalia of our degree, a maroon blazer featuring the Moose Legion logo, with coordinating tie, white shirt, black trousers and accessories. Moose Legionnaires who have been elevated to honorary degrees of our Order wear blazers of different colors – French Blue for those who have received the Fellowship Degree of Honor and Gold for those who have been bestowed with the highest degree of our Order, the Pilgrim Degree of Merit. While the colors may be different, all three blazers represent similar qualities, commitment to this fraternity, to its honored past and to its strong and bright future.

Everyone please rise (**Pause**) as Faith offers prayer.

*(Loyalty gestures the class and staff to rise as the words “Everyone please rise” are spoken. His attention shall be on the class.)*

*(When his charge is completed, Loyalty turns left, steps off with his left foot, returns to Position 5 with station on his left, turns left and remains standing.)*

*(As Loyalty breaks Position 8, Faith, exits Position 2 with station on left and advances to Position 1. He does not*

*begin the prayer until Loyalty is standing at Position 5.)*

*(Faith will demonstrate his instructions for folding arms and bowing heads. Movements will be performed after each instruction is given. Movements of staff members shall be done in unison with Faith. Staff members' arms must be folded uniformly. After assuming prayer posture, Faith slowly raises his head to normal speaking position and delivers his prayer.)*

**FAITH:** Let us fold our arms (**Pause**) and bow our heads. (**Pause**) Almighty God, we give thanks for these new Moose Legionnaires. We pray that our experience here today will provide a positive and lasting influence. May the words we have heard be an inspiration unto our hearts; may we go forth with a better understanding of the good we do, and more dedicated to our cause than ever before.

Bind us together and instill in our hearts the caring and devotion to our cause and help us to see that cause carried out through the fulfillment of the pledge we have freely taken.

May we truly enjoy the warmth and goodness of making a positive difference in the lives of others. We ask that a special blessing be bestowed upon all the men and women of the Moose, and each member of their families, and may that same divine blessing touch every part of this great fraternity itself. Amen.

*(At the completion of the prayer, Faith will hold his position until staff has repeated "Amen". Faith does not re-bow his head. The staff and Faith break prayer posture in unison. Prayer posture is broken by first raising the head, then lowering the arms.)*

*(After breaking prayer posture, Faith turns right, steps off*

*with his right foot, returns to Position 2 with station on his left, turns left and remains standing.)*

*(The Conferral President does not rap the gavel until Faith has returned to his station and is turned at his chair, then gives one rap. After rapping the gavel, he shall gesture to seat everyone as he says, "Everyone please be seated." Staff members, with the exception of the President, seat themselves in unison. He remains standing himself, and pauses for everyone to be seated before addressing class.) Conferral President delivers charge in Position 4):*

**CONFERRAL PRESIDENT:** Everyone please be seated. **(Pause)** Moose Legionnaires, you have accepted our invitation and joined with us in our worthwhile endeavor. You deserve the gratitude and admiration of Moose members everywhere.

You are now a part of a higher degree of our Order, and are eligible to become a member of the Council of Higher Degrees and support their fraternal efforts.

Be ever mindful of the promises made today. Never pass up an opportunity to demonstrate, in word and deed, the characteristics of Faith, Hope, Charity, and Loyalty, the cornerstones of our Degree.

As the staff retires from the floor (Pause as staff rises in unison) our conferral will come to a close.

*(Following the word "floor", the Conferral President pauses to allow staff members to rise. After completing his charge, the Conferral President moves left and proceeds to his vacating position. As the Conferral President begins his motion, the remaining staff members move in unison to their respective vacating positions. All staff members shall be facing forward.) (After a slight pause, the Conferral President will step off on his left foot and proceed toward Position 10 (per Diagram 3).*

*Loyalty will fall into line behind the Conferral President. Hope will fall into line behind Loyalty. All three will stop at a point 90 degrees to their chairs and centered. After a short pause, the Conferral President, Loyalty and Hope will turn right and be seated. In unison with the Conferral President, the Orator will step off on his right foot and proceed toward Position 9 (per Diagram 3). Charity will fall into line behind the Orator. Faith will fall into line behind Charity. All three will stop at a point 90 degrees to their chairs and centered. After a short pause, the Orator, Charity and Faith will turn left and be seated. Movements by all staff members on vacating shall be performed in unison.) (After the - Conferral Staff has retired, the directors and appointed officers resume their positions.)*

**PRESIDENT:** I would ask that our - Conferral President introduce himself and the other members of the staff.

**CONFERRAL PRESIDENT:** Thank you, President (*first name*).

In the part of Orator, (*first and last name*).

In the part of Faith, (*first and last name*).

In the part of Hope, (*first and last name*).

In the part of Charity, (*first and last name*).

In the part of Loyalty, (*first and last name*).

And I am (*first and last name*), serving as - Conferral President.

**PRESIDENT:** Our sincere thanks to the members of the Conferral Staff for conferring the Degree of Service upon our newest Moose Legionnaires. We welcome all of our new members into our Moose Legion.

Please attend the meetings and functions of the Lodge Moose Legion Committee in your lodge whenever possible. Your involvement is encouraged and gives you an opportunity to participate in Moose Legion programs between Celebrations.

We also invite you to attend and enjoy our jurisdictional meetings and functions. We look forward to having you



back with us at future jurisdiction Celebrations.

## INFORMATIONAL MEETING AGENDA

**PRESIDENT:** We will now continue with other informational topics that will help bring our new and longtime members up to date with who we are and share some of the plans our Moose Legion has in place for upcoming activities.

6. *Communication and Notices*
7. *Reports of Standing and Special Committees*
8. *Sickness and Distress*
9. *Good of the Moose Legion*
10. *Official Visitors or Invited Guest Comments*
11. *Installation of Directors (If Conducted at Annual Celebration)*

*(See INSTALLATION CEREMONY at page 79.)*

## ENDOWMENT FUND

**PRESIDENT** *(Gives one rap):* The Nine O'clock Ceremony has special meaning for every Moose Legionnaire. Today, we have the privilege to repeat this special prayer and add our contributions to the Mooseheart/Moosehaven Endowment Fund.

**PRESIDENT** *(Gives two raps):* Everyone please rise as Fraternal Director *(first name)* leads us in the Nine O'clock Ceremony.

**FRATERNAL DIRECTOR:** It is now Nine O'clock. At this time the little children at Mooseheart kneel at their beds to say their evening prayers. Let us face toward Mooseheart, *(Fraternal Director gestures in the direction of Mooseheart)* fold our arms, bow our heads and join

them in silent prayer.

*(The room lights are turned low but not off, and chimes are sounded nine times slowly. After the ninth stroke, the Fraternal Director begins the prayer.)*

**FRATERNAL DIRECTOR:** Repeat after me. Let the little children come to me.

**MEMBERS:** *(Repeat)*

**FRATERNAL DIRECTOR:** Do not keep them away.

**MEMBERS:** *(Repeat)*

**FRATERNAL DIRECTOR:** For they are like the kingdom of Heaven.

**MEMBERS:** *(Repeat)*

**FRATERNAL DIRECTOR:** God bless Mooseheart.

**MEMBERS:** *(Repeat)*

**FRATERNAL DIRECTOR:** Amen.

**MEMBERS:** *(Repeat)*

**PRESIDENT** *(Gives one rap):* Please be seated. *(Pause)* The Endowment Fund was created by the Moose Legion in 1913 to assure the continued operation of Mooseheart and Moosehaven. Today, this fund provides significant financial assistance to our 'Child City' and our 'City of Contentment'. We encourage each of you to continue this tradition of giving today, and during your Lodge Moose Legion Committee meetings and functions. The Sergeant-at-Arms will now collect your contributions. The total collected will be remitted to Moose Charities and credited to the Endowment Fund.

*(While contributions are being received, the President may call on the Fraternal Director to announce any current or future Endowment Fund activities.)*

## CLOSING CEREMONY

**PRESIDENT:** Our business being concluded, we will proceed to close. *(Gives two raps) (Pause)* What is our duty and responsibility as members of the Moose Legion? All Moose Legionnaires will repeat after me: *(Pause)* To aid and assist – in the strengthening of our Order – and every unit thereof; - and to support every effort – for the protection and care – of our children at Mooseheart – and our senior members at Moosehaven, - so their future years – may be full of sunshine and contentment.

**PRESIDENT:** Chaplain *(first name)* will deliver the closing prayer.

*(The Chaplain proceeds to Position 1.)*

**CHAPLAIN:** Let us fold our arms *(Pause)* and bow our heads. *(Pause)* Heavenly Father, we thank Thee for the opportunity to meet as members of the Degree of Service. Grant us the courage to practice our principles of Faith, Hope, Charity and Loyalty in our everyday lives. Prosper the cause of childhood and old age everywhere, and make each of us a more worthy exponent of that cause. Let us return safely home with renewed determination to serve Thee and our fellow man through the channels of this Fraternity. All this we ask in Thy name. Amen.

*(The Chaplain returns to his station and remains standing.)*

**PRESIDENT:** Sergeant-at-Arms *(first name)* will close the Bible and fold the Charter. *(The Sergeant-at-Arms proceeds to Position 1, closes the Bible, folds the Charter, places the closed Bible on top of the folded Charter, then returns to his chair and remains standing.)*

**PRESIDENT:** Thank you for attending. This Moose Legion is now closed until called to meet by the Board of Directors. I bid you all Good *(Day/Afternoon/Night)*.



## LINE OF MARCH FOR VACATING

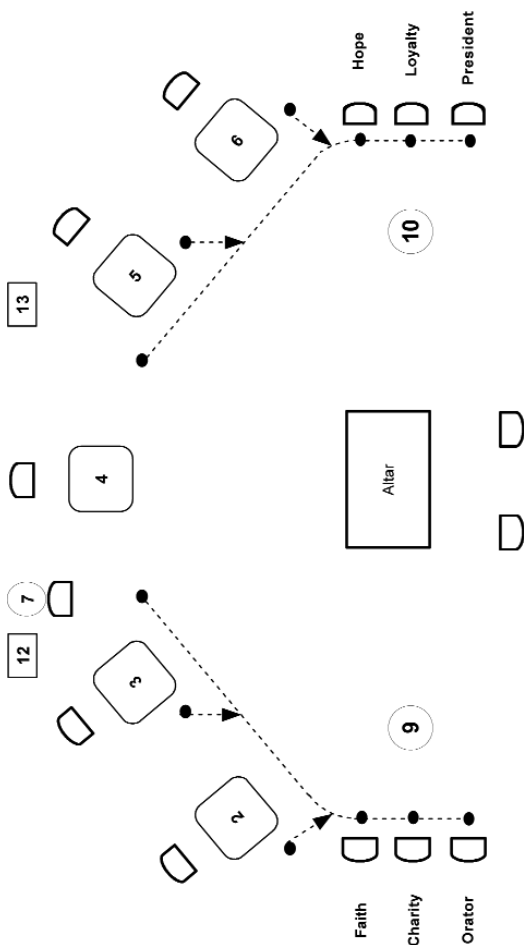

Diagram No. 3

## FLOOR POSITIONS

- 1  
2 These instructions cover work on a standard size floor,  
3 requiring spacing of 12 feet from the front of each station  
4 to the center of the Altar and remaining distances adjusted  
5 as necessary. Sufficient spacing shall be allowed for the  
6 class behind the Altar (see Diagram 1 on page 5).
- 7 Position 1 – Sergeant-at-Arms, President, - Conferral  
8 President, Faith and Chaplain position at the  
9 Altar, centered, facing class, and toes within  
10 eighteen (18) inches of the Altar edge.
- 11 Position 2 – Chaplain and Faith station
- 12 Position 3 – Fraternal Director and Charity station
- 13 Position 4 – President station
- 14 Position 5 – Junior Past President and Loyalty station
- 15 Position 6 – Vice-President and Hope station
- 16 Position 7 – Sergeant-at-Arms and Orator chair three (3)  
17 feet to the right of the President station, with  
18 front edge of chair in line with back edge of  
19 the President station.
- 20 Position 8 – An area located between the Altar and the  
21 President's station, with the back edge five  
22 (5) feet from edge of Altar. The area is as  
23 wide as a standard Altar (32"). Toes should  
24 be within these limits at all times while  
25 addressing the class.
- 26 Position 9 – Chairs for Orator, Charity and Faith twelve  
27 (12) feet from center of Altar. Left edge of  
28 Orator's chair in line with the edge of the  
29 Altar closest to the President's station.
- 30 Position 10 – Chairs for Conferral President, Loyalty and  
31 Hope twelve (12) feet from center of Altar.  
32 Right edge of - Conferral President's chair  
33 in line with the edge of the Altar closest to  
34 the President's station.
- 35 Position 11 – Class chairs four (4) feet from Altar and  
36 centered. (For competition – two (2) chairs,  
37 four (4) feet from Altar and centered with  
38 three (3) feet between chairs.)

Position 12-	National flag	1
Position 13-	Optional State, Provincial or Moose Legion flag	2
Position 14-	Chaplain position for opening prayer and Sergeant-at-Arms position for balloting on candidates, toes within eighteen (18) inches of Altar and centered, facing side of Altar.	3 4 5 6
Position 15-	Assistant-Sergeant-at-Arms position for balloting on candidates (when applicable), toes within eighteen (18) inches of Altar and centered, facing side of Altar.	7 8 9
Position 16-	Conferral President moves to a position prior to vacating that matches that of the Orator. (Vacating positions of the Orator and President are to mirror each other.)	10 11 12 13
Position 17-	Faith position prior to vacating	14
Position 18-	Charity position prior to vacating	15
Position 19-	Orator moves straight forward from his chair to a position where his feet are the same distance forward or back of the front edge of the President's station, as are the other team members at their stations. (forward or back from the front edge) (Vacating positions of the Orator and President are to mirror each other.)	16 17 18 19 20 21 22
Position 20-	Loyalty position prior to vacating	23
Position 21-	Hope position prior to vacating	24

## FLOOR MOVEMENTS

The Conferral Ceremony and judging for competition begins when the Conferral Staff Captain indicates the staff is ready by taking his seat, and will end when the staff is seated uniformly in Positions 9 & 10 after vacating. Position of hands when seated should be uniform.

The Conferral Staff shall rise in unison immediately after the Moose Legion President or Conferral Judge says "begin", and leave Positions 9 & 10 in unison as shown in Diagram No. 2 on page 36. Staff members seated in

1 Position 9 shall take one step forward in unison, leading  
2 off with the left foot and turning left 90 degrees to the chair  
3 and centered. After a short pause, the Orator will step off  
4 on his right foot, proceed directly to his chair and turn  
5 right, centered on chair and facing forward.

6 Charity will follow after one (1) step of the Orator by  
7 stepping off on his left foot and proceeding directly to his  
8 station. Charity enters with the station on his right, turns  
9 right at his chair and faces forward.

10 Faith will follow after one (1) step of Charity by stepping  
11 off on his right foot and proceeding directly to his station.  
12 Faith enters with the station on his right, turns right at his  
13 chair and faces forward.

14 Staff members seated in Position 10 shall take one step  
15 forward in unison, leading off with the right foot and  
16 turning right 90 degrees to the chair and centered. After a  
17 short pause, the Conferral President will step off on his  
18 left foot and proceed directly to his station. The Conferral  
19 President enters with the station on his left, turns left at his  
20 chair and faces forward. Loyalty will follow after one (1)  
21 step of the Conferral President by stepping off on his right  
22 foot and proceeding directly to his station.

22 Loyalty enters with the station on his left, turns left at his  
23 chair and faces forward. Hope will follow after one (1)  
24 step of Loyalty by stepping off on his left foot and  
25 proceeding directly to his station.

26 Hope enters with the station on his left, turns left at his  
27 chair and faces forward. Movements by all staff members  
28 on entry shall be performed in unison.

29 After each member of the Conferral Staff is at his chair or  
30 station, the Conferral President will rap the gavel once to seat  
31 the staff and gesture accordingly. He remains standing himself,  
32 and pauses for staff to be seated before addressing class.

33 The Conferral President will begin his initial charge from  
34 Position 4. After the words "Degree of Service",



The Conferral President exits Position 4 with station on his left and proceeds to Position 8. He shall continue speaking as he moves from Position 4 to Position 8. When his charge is completed, he turns left, steps off with his left foot, returns to Position 4 with station on his left, turns left and is seated.

The Orator rises as the Conferral President breaks Position 8. He steps off with his left foot and proceeds to Position 8 to deliver his charge. The Orator does not begin speaking until the President is seated. When his charge is completed, he turns right, steps off with his right foot, returns to Position 7, turns left and is seated.

Faith rises as the Orator breaks Position 8. He exits Position 2 with station on his left and proceeds to Position 8 to deliver his charge. Faith does not begin speaking until the Orator is seated. When his charge is completed, he turns right, steps off with his right foot, returns to Position 2 with station on his left, turns left and is seated.

Hope rises as Faith breaks Position 8. He exits Position 6 with station on his left and proceeds to Position 8 to deliver his charge. Hope does not begin speaking until Faith is seated. When his charge is completed, he turns left, steps off with his left foot, returns to Position 6 with station on his left, turns left and is seated.

Charity rises as Hope breaks Position 8. He exits Position 3 with station on his left and proceeds to Position 8 to deliver his charge. Charity does not begin speaking until Hope is seated. When his charge is completed, he turns right, steps off with his right foot, returns to Position 3 with station on his left, turns left and is seated.

The - Conferral President rises as Charity breaks Position 8. He exits Position 4 with station on his left and proceeds to Position 1 to deliver the obligation. The Conferral President gestures the class and staff to rise as the words "Please stand" are spoken. His attention shall be on the class. He will demonstrate his instructions for raising the right hand

1 and placing the left hand over the heart. Movements will  
2 be performed after each instruction is given.

3 The Conferral President lowers his hand after saying the  
4 words "You may lower your hands". He will gesture the  
5 class and staff to be seated as the words "You may be  
6 seated" are spoken.

7 Movements by staff members shall be done in unison with  
8 the Conferral President. Staff members shall repeat the  
9 obligation along with the class.

10 When the charge is completed, the Conferral President  
11 turns left, steps off with his left foot, returns to Position 4  
12 with station on his left, turns left and is seated.

13 Loyalty rises as the Conferral President breaks Position 8.  
14 He exits Position 5 with station on his left and proceeds to  
15 Position 8 to deliver his charge. Loyalty does not begin  
16 speaking until the Conferral President is seated.

17 Loyalty gestures the class and staff to rise as the words  
18 "Everyone please rise" are spoken. His attention shall be  
19 on the class.

20 When his charge is completed, he turns left, steps off with  
21 his left foot, returns to Position 5 with station on his left,  
22 turns left and remains standing.

23 Faith leaves position 2 as Loyalty breaks position 8. He exits  
24 Position 2 with station on his left and proceeds to Position  
25 1 to deliver the prayer. He will demonstrate his instructions  
26 for folding arms and bowing heads. Movements will be  
27 performed after each instruction is given. Movements of  
28 staff members shall be done in unison with Faith.

29 Staff members' arms must be folded uniformly. After  
30 assuming prayer posture, Faith slowly raises his head to  
31 normal speaking position and delivers his prayer.

32 At the completion of his prayer, Faith will hold his position  
33 until staff has repeated "Amen" (Faith does not re-bow  
34 head). The staff and Faith break prayer posture in unison.

Prayer posture is broken by first raising the head, then lowering the arms. Faith turns right, steps off with his right foot, returns to Position 2 with station on his left, turns left and remains standing.

The Conferral President will rap the gavel once to seat everyone after Faith has returned to his station and is turned at his chair. After rapping the gavel, he shall gesture to seat everyone as he says, "Everyone please be seated." He remains standing himself, and pauses for everyone to be seated before addressing class.

Following the word "floor", the Conferral President pauses to allow staff members to rise. After completing his charge, the Conferral President moves left and proceeds to his vacating position as per diagram 3, page 37. As the Conferral President begins his motion, the remaining staff members move in unison to their respective vacating positions. All staff members shall be facing forward. Forward is the same direction as his station faces.

After a slight pause, the Conferral President will step off on his left foot and proceed toward Position 10 (per Diagram 3). Loyalty will fall into line behind the Conferral President. Hope will fall into line behind Loyalty. Loyalty and Hope will be in step with the Conferral President. All three will stop at a point 90 degrees to their chairs and centered. After a short pause, the Conferral President, Loyalty and Hope will turn right and be seated.

In unison with the Conferral President, the Orator will step off on his right foot and proceed toward Position 9 (per Diagram 3). Charity will fall into line behind the Orator. Faith will fall into line behind Charity. Charity and Faith will be in step with the Orator. All three will stop at a point 90 degrees to their chairs and centered. After a short pause, the Orator, Charity and Faith will turn left and be seated.

Movements by all staff members on vacating shall be performed in unison. To show the importance of the ceremony, staff members should maintain a dignified manner

1 with hands in uniform position for a few seconds during a  
2 competition or until otherwise specified at a meeting.

### 3 **GENERAL INSTRUCTIONS**

4  
5 Staff members will avoid looking at the floor at any time.

6 When folding arms, arms must be folded uniformly. When  
7 placing left hand over heart, hands must be uniform in  
8 their placement.

9  
10 All staff members seated at stations will enter and leave their  
11 stations with station on their left, with the exception of Faith  
12 and Charity during entry of staff at the beginning of the  
13 ceremony and President, Loyalty and Hope during vacating at  
14 end of ceremony. Members may not put their hands upon their  
15 stations. Members must not put their hands on their chairs to  
16 rise or be seated unless granted permission by the judges.  
17 Touching the Altar cloth or brushing against the Altar or  
18 stations is not a violation; however, kicking chairs, stations or  
the Altar, or dropping the gavel is not permitted.

19 When a staff member rises from his chair for the purpose  
20 of moving to a floor position, he may pause before  
21 stepping off, but once started he must continue without  
22 interruption until he has reached his position.

23 A ritualist may move within the parameters of Position 8  
24 after establishing the position, but his toes must remain  
25 within its boundaries during his charge.

26 Being natural and impressive are the most important  
27 elements of a successful Conferral Ceremony. The  
28 delivery of the charge to the candidates in a meaningful  
29 and memorable manner is by far the primary concern, and  
30 thus should be the same during competition. All  
31 movements should be graceful.

32 While moving and speaking in Position 8, a staff member  
33 may only use his right hand when turning right or moving  
34 to the right, and only his left hand when turning left or

moving to the left. He should never turn his back on the candidates while speaking. 1  
2

“A ritualist breaks Position 8” is defined as the time after a pivot or turn between his first foot crossing the outer edge of Position 8, and his last foot to leave Position 8 and touch the floor outside of Position 8. 3  
4  
5  
6

When the attention of the speaker is not on the class, because he is using a gesture to a person, place or thing he must center his body in that direction. The direction of Mooseheart is to the speakers left and Moosehaven to his right. Centering the body means turning both feet in that direction. This also applies to the Conferral President when he is speaking from Position 4. 7  
8  
9  
10  
11  
12

Staff members must turn left and step off on their left foot to go left, and must turn right and step off on their right foot to go right. The turn is made by a slight pivot on the ball of the opposite foot, then stepping off the required foot. Do not turn both feet at the same time. Stepping off is defined as raising the foot and moving it in the direction of the intended move. 13  
14  
15  
16  
17  
18

When the Conferral President, Hope and Loyalty leave Position 8, they turn left and step off on their left foot to return to their stations. The Orator, Faith and Charity turn to their right and step off on their right foot to return to their positions. 19  
20  
21  
22

All staff members should move to and from floor positions 8 or 1 naturally and by the shortest route possible. Once in position 8 or 1, stop to establish the position and begin speaking before moving within the position, except on entering and vacating or where movements are prescribed. A side step may be taken when leaving a chair at a station. 23  
24  
25  
26  
27  
28

There will be no unnecessary delay in following the Conferral President’s instructions, including raps of the gavel. The Conferral President does not seat himself after one rap. 29  
30  
31

Heads may be turned at any time for the purpose of watching the movements of others. Heads shall be turned to put attention on the Conferral president when he is speaking. 32  
33  
34

## GESTURES

1  
2 A gesture is an expressive movement of the body, or part  
3 of the body, used to emphasize an idea, emotion, action or  
4 specific point.

5 Timely hand gestures that are smooth and natural should be  
6 used during every charge. A gesture is most effective when it  
7 is made at the same time as the related words are spoken.  
8

9 Nodding or shaking the head may be used to emphasize  
10 meaning, but constant movement of the head is prohibited.  
11 Staff members should use relaxed, open-handed gestures.  
12 They may use fingers or relaxed-close handed motions to  
13 emphasize a point. They may not point at a person, place or  
14 thing with one finger or use a clenched fist. When not  
15 gesturing, hands should be in front of the body or at the sides.  
16 Hands or fingers may be clasped, but should not be held  
17 behind the back, placed in pockets or placed on hips. When  
18 gesturing in the direction of the Altar or class, a ritualist may  
19 use either or both hands. When gestures are made to help  
20 express oneself and attention is still on the class, the hand or  
21 hands may be extended to the side and away from the body.  
22 Constant use or movement of the hands is permitted, and  
23 either or both hands may be used for gestures. Looking at the  
24 hands when gesturing is not a violation.

25 A staff member should not rock on his feet, continually  
26 bob or shake his head, or permit his hands to indicate  
27 nervousness. He should do nothing with his head, hands or  
28 body that will distract from his presentation.

29 Gestures should be made as words are spoken when  
30 motioning the class or staff to rise or be seated.

## ATTENTION AND SPEAKING

31 Unless otherwise directed, each staff member must begin  
32 and complete his charge in Position 8 while facing the  
33 class. He must stop and establish position before speaking  
34 or moving. A staff member may move within Position 8  
except as indicated.

While in Position 8, staff members shall speak only to the class except when gesturing to a person, place or thing. Staff members need not complete a sentence before shifting attention.

A nod of the head SHOULD NOT be given upon the completion of a charge. Avoid dropping the voice at the end of a sentence. Enunciate clearly, pronounce words correctly and speak in a natural voice.

The Conferral Staff shall be attentive at all times and have their attention on the person speaking. The staff should be uniform in positioning their hands while seated, and should do nothing to cause distraction while at their chairs or stations.

Staff members should be friendly and relaxed when delivering their charges. They should refrain from a monotone or singsong delivery. The charge should be delivered with impressiveness. The ceremony is not intended to be humorous, but an occasional friendly smile will add to impressiveness. Speaking parts should be delivered in full and exactly as written.

## **RULES OF CONFERRAL COMPETITION**

All State/Provincial Moose Legion - Conferral Competitions will be under the jurisdiction of the Association Conferral Chairman. He shall appoint the Chairman of the Competition Committee and the Chairman of the Judging Committee, subject to the approval of the Director of Moose Legion. The Association Conferral Chairman is responsible for selecting a time for the competition. Out-of- state judges are not permitted to serve as chairman of either the Competition Committee or the Judging Committee.

The Chairman of the Competition Committee may not compete in the State/Provincial Conferral Competition. The chairmen and all judges must be Moose Legionnaires in active status.

Only staffs from Moose Legions in active status with the

1 International Moose Legion are eligible to enter State/  
2 Provincial, Regional or International Conferral Competitions.

3 All Moose Legion members are eligible to compete in  
4 State/Provincial, Regional or International Conferral  
5 competitions, with the exception of the current  
6 International Judging Staff members.

7 A Conferral Staff shall consist of a Conferral President,  
8 Orator, Faith, Hope, Charity and Loyalty. Clothing should  
9 be uniform; any appropriate and dignified manner of dress  
10 is acceptable.

11 The only exceptions to uniform dress are wearing apparel  
12 of each member's degree (official regalia or degree polo  
13 shirt). All medals described in Section 30.2 of the Moose  
14 Legion Code of Rules may be worn, but only with official  
15 regalia. Competitors may not wear medallions of any kind  
during competition.

16 During competitions, the Conferral Ceremony shall be  
17 presented to two Moose Legionnaires serving as  
18 candidates. All Conferral Staffs are responsible for  
19 furnishing their own class members.

20 **JUDGES:** The Director of Moose Legion must sanction  
21 all judges for International, State/Provincial and Regional  
22 Conferral Competitions. A list of qualified judges is  
23 available from the department.

24 **JUDGING:** Competing teams will be judged on ritualistic  
25 accuracy, delivery, general effect, appeal to candidates and  
26 individual floor work. A perfect team score is 600 points  
27 (100 points possible for each staff member).

28 Tabulator will check all judging sheets to insure Conferral  
29 Accuracy, Delivery, General Effect, Candidate Appeal and  
30 Individual Floor Work, to assure that the same information  
31 is contained in the book.

32 **RITUALISTIC ACCURACY** (50 Points): For every  
33 word omitted, added, transposed, slurred or substituted in  
34 the spoken parts of the Conferral Ceremony; or for each



indicated pause omitted or added in the repeated portions of the obligations, 1/8 point will be deducted. For each prompt given, 1/2 point will be deducted. A prompt will consist of the number of words necessary for the speaker to recover. Multiple prompts may be given, but sound judgment should be exercised before doing so.

**DELIVERY** (8 Points): Speaking – 4 Points (1/4 point penalty: too fast, too soft, too soon, too late, monotone, singsong, poor pronunciation); Gestures – 4 Points (1/4 point penalty: not graceful, forbidden gesture used, wrong hand used, not enough gestures, required gesture missed, gestures not timely, incorrect body position).

**GENERAL EFFECT AND CANDIDATE APPEAL** (26 Points): General Appearance – 2 Points (1/4 point penalty: untidiness of clothes, person or grooming; shoes not shined, tie not straight, attire not uniform); Attention to Class – 4 Points (1/4 point penalty: not enough, too much, untimely); Impressiveness – 20 Points (score assigned at judge's discretion, increments of 1/32 of a point are used, i.e. .0000, .03125, .0625, .09375, .1250, .15625, .1875, .21875, .2500, .28125, .3125, .34375, .3750, .40625, .4375, .46875, .5000, .53125, .5625, .59375, .6250, .65625, .6875, .71875, .7500, .78125, .8125, .84375, .8750, .90625, .9375, .96875. Impressive scores reflect the speaker's ability to enunciate clearly, to express himself properly, to move while speaking and use proper gestures smoothly, to project confidence in a relaxed and friendly manner, and to speak in a natural voice.

**INDIVIDUAL FLOOR WORK** (16 Points): Entering and Vacating – 4 Points (1/4 point penalty: looking at floor, not correct, too military, confused); Entering and Leaving Stations – 4 Points (1/4 point penalty: untimely, careless, incorrect, looking at floor, not uniform); Floor Positions and Movements – 6 Points (1/4 point penalty: incorrect, not uniform, looking at floor, inattentive, untimely, careless); Conduct at Stations – 2 Points (1/4 point penalty: inattentive, tense, restless, not uniform).

1  
2  
3  
4  
5  
6  
7  
8  
9  
10  
11  
12  
13  
14  
15  
16  
17  
18  
19  
20  
21  
22  
23  
24  
25  
26  
27  
28  
29  
30  
31  
32  
33  
34

1 **ENTRIES:** Entries for competing staffs must be sent to  
2 the Chairman of the Competition Committee before the  
3 publicized deadline. Before competing, the Conferral Staff  
4 captain or authorized representative of the staff should  
5 report any substitutions to the Chairman of the  
6 Competition Committee. After an entry is submitted, no  
7 more than three substitutions are permitted.

8 Before being able to participate in State/Provincial or  
9 International Conferral Competitions, all ritualists and  
10 class members must be officially registered at the  
11 corresponding convention, conference or celebration. The  
12 Chairman of the Competition is responsible for securing  
13 an adequate room for competition and assuring that the  
14 room is set up properly. The following items are required:  
15 stations, chairs, Altar, Bible, flag, gavel and Altar and  
16 station covers. When all paraphernalia has been placed for  
17 competition, station chairs and chairs in Positions 9 & 10  
18 may be moved to satisfy each team, except the chairs of  
19 the Orator and President may not be moved.

20 The Chairman of the Judging Committee will assume full  
21 responsibility for conducting a proper competition and  
22 enforcing all applicable rules. He is the final authority on  
23 interpretation of the rules and is authorized to "NO  
24 CHARGE" any "hit" he feels is questionable. Judges may  
25 not make any changes to their sheets once they have been  
26 given to Chairman, except to make clarifications.

27 Decisions of the Chairman of the Judging Committee are  
28 final, and only tabulation errors or undisputed posting errors  
29 will be corrected. The Chairman will set the time limit for  
30 corrections to be made.

31 When tabulation errors or posting errors are reported  
32 within the time limit and awards have been presented, a  
33 duplicate award is presented and there is a tie for the place  
34 in question.

When places of finish have been announced, teams and individuals with adjusted scores will be placed in a tie with teams or individuals scoring the same or next fewest points. Two Word Judges and a minimum of two approved out-of-state Floor Judges shall be used in all competitions having six or more teams. When there are fewer than six teams in a competition, one approved out-of-state Floor Judge may be used **WITH THE PERMISSION OF THE DIRECTOR OF MOOSE LEGION.**

Out-of-state Conferral Judges are not to accept responsibility as either Chairman of the Competition Committee or Chairman of the Judging Committee.

They are also not to attend a conferral just prior to competition to view a competing staff in action.

Judge No. 1 is seated between Position 10 and the class.

Judge No. 2 is seated between Position 9 and the class. If only one judge is used, he may judge from either of these positions. One Word Judge will do the word judging and the other will do the prompting. The Word Judge and the Prompter are seated behind Position 10. Judge No. 3 is seated behind Position No. 9.

Members of the Loyal Order of Moose who do not belong to the Moose Legion are not permitted to view Moose Legion Conferral Competitions. Those in attendance shall remain quiet and maintain proper decorum. Spectators and competing ritualists are not permitted to move about, smoke, drink alcoholic beverages, display or use any papers or books, make any notes, or use any recording devices while a staff is competing. **Cellular phones and other electronic devices must be turned off.**

A ritualist who holds multiple memberships may compete with multiple staffs in any competition provided the ritualist is in active status in the respective Moose Legion

1 jurisdiction. A ritualist will only receive one award for his  
2 highest score. A Conferral Staff member may be used as a  
3 fill-in on any staff qualified to compete if he has already  
4 competed. A fill-in will not be scored, but may be used as  
5 a class candidate prior to competing.

6 The Chairman of the Judging Committee, the Tabulator  
7 and all judges may not compete in any competition in  
8 which they are associated, nor may they be used as a fill in  
9 or as a class candidate. The Moose Legion Secretary must  
10 certify on the Conferral Competition Entry Form that each  
11 staff member is active status in his Lodge and in the Moose  
12 Legion for which he is competing.

13 A team must report for competition 30 minutes prior to  
14 their scheduled time, unless an acceptable excuse is made  
15 to the Chairman of the Judging Committee by a  
16 representative of the team. The burden of proof for an  
17 acceptable excuse will be on the team. When the excuse  
18 has been found to be acceptable, the team will be  
19 rescheduled to the end of the competition, or earlier if  
20 circumstances permit.

21 If an emergency occurs prior to or after arrival at the place  
22 of competition, any member of the Moose Legion may be  
23 used as a fill-in and may read or recite the part for the  
24 purpose of permitting other staff members to compete for  
25 individual awards. The fill-in will not be judged, nor will  
26 he receive a score. This provision does not apply to any  
27 team using a qualified substitution.

28 There may be an occasion when a staff member is unable  
29 to continue, even after the staff has reported and entered  
30 into competition. Should this occur, activity will  
31 immediately cease and the team may be rescheduled to the  
32 end of competition, or earlier if circumstances permit.

33 Score sheets will be marked at the time of interruption.  
34 Although a member may commence again from the

- their opinion, a staff member appears to be ill. 1
- Judges are not permitted to leave their positions or make 2  
any distracting moves while a staff is on the floor. They 3  
shall not converse with one another until their sheets have 4  
been completed and turned in to the Chairman. Word 5  
Judges may ask for assistance from the Prompter after a 6  
staff is off the floor, but this should not take place in a 7  
manner that others can hear. Immediately after competing, 8  
a Conferral staff must exit the floor **without conversing** 9  
**with any Floor Judges or Word Judges. A ¼ point** 10  
**penalty may be assessed on any ritualist determined to** 11  
**be in violation of this provision.** 12  
13
- All spectators must vacate the competition room with the 14  
team and may return when the next team enters the room. 15  
16
- Judges shall not converse with any ritualists concerning 17  
errors or make any suggestions until the entire competition 18  
has been completed and results have been distributed. 19  
However, the Chairman of the Competition Committee  
may answer questions prior to a ritualist appearing on the  
floor.

## CERTIFICATE OF AUTHENTICATION

We, the undersigned, hereby certify that we have carefully inspected this revised edition of the Opening, Closing and Conferral Ceremonies of the Moose Legion. We acknowledge that these ceremonies supersede and replace all prior editions as approved by the International Moose Legion Council and adopted by the Supreme Council.

In witness whereof, we have hereunto subscribed our names and affixed the seal of the International Moose Legion this 1st day of May 2018.



*Robert A. Neff*

Robert A. Neff  
Director of  
Moose Legion

*Michael L. Hauf*

Michael L. Hauf  
President  
International Moose Legion

*Guidelines For*  
**NOMINATING  
AND ELECTING**



**MOOSE LEGION  
DIRECTORS**

*The Moose Legion is  
known as the*  
**DEGREE OF SERVICE**

*OUR MISSION. . .*

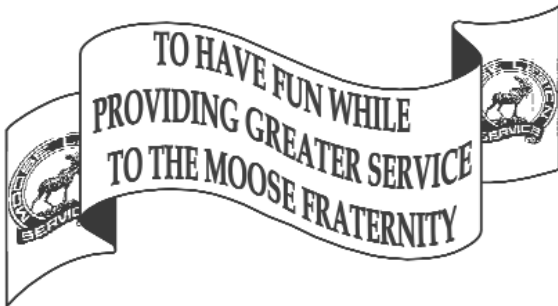

*OUR VISION. . .*

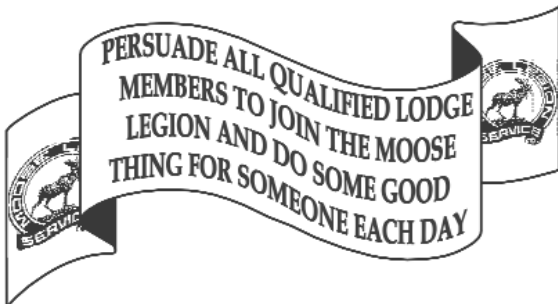



## FOREWORD

The enclosed information and guidelines are intended as a useful tool that will clarify the process of electing Directors and ensuring a smooth transition of leadership for the Moose Legion and its membership.

These guidelines in no way supersede the Moose Legion Code of Rules or the Constitution and General Laws of the Loyal Order of Moose, currently in effect, both of which should be thoroughly reviewed.



Director - *One of a group of persons entrusted with the overall direction of a corporate enterprise.*

## CONTENTS

FOREWORD.....	57
NOMINATING COMMITTEE	
<i>(Reference Chapter 11 of the Code of Rules)</i>	
Organization .....	59
Composition.....	59
Meetings .....	59
Responsibilities.....	59
Report to the Membership.....	60
Dissolution.....	60
CAMPAIGNING.....	60
ELIGIBILITY OF NOMINEES .....	60
DIRECTOR QUALIFICATIONS .....	
Board of Directors .....	61
President .....	62
ELECTION COMMITTEE.....	62
INSTALLATION OF DIRECTORS .....	63
VACANCIES.....	63
ELECTION OF DIRECTORS .....	64
VOTING .....	
By Ballot.....	64
By Sign of the Order .....	64
Sample Ballot .....	65
QUESTIONS AND ANSWERS .....	66
RESPONSIBILITIES OF ELECTED DIRECTORS...71	
<i>(Code of Rules Chapters 12 - 17)</i>	
President .....	71
Vice-President.....	73
Chaplain.....	73
Fraternal Director .....	74
Financial Director .....	75
CONCLUSION .....	76

---

## **NOMINATING COMMITTEE**

### **(Code of Rules Chapter 11.3)**

#### **Organization**

Every Moose Legion is required by the Code of Rules to hold an election of directors during the Annual Celebration scheduled between March 1 - April 30 of each year. The five (5) elected directors are President, Vice-President, Chaplain, Fraternal Director and Financial Director. The only exceptions are: (1) a newly instituted Moose Legion, (2) a Moose Legion that has received written permission from the International Moose Legion Director, or (3) an emergency situation requiring an election to be changed or waived.

The Nominating Committee is probably the most important committee of the Moose Legion. Selection of qualified candidates will ensure success for the Moose Legion.

#### **Composition**

The Nominating Committee consists of:

The Board of Directors (7)

The duly appointed Assistant Secretaries representing the Lodges within the jurisdiction.

#### **Meetings**

The Nominating Committee meets at least forty-five (45) days prior to the Annual Celebration scheduled between March 1 – April 30 of each year, to select candidates for the Board of Directors. The Secretary shall advise each member of the Nominating Committee of the date of this meeting at least thirty (30) days in advance.

#### **Responsibilities**

The Nominating Committee has three main responsibilities:

1. Work with diligence to secure the best possible Directors obtainable
2. Select at least one (1) Moose Legionnaire for each elected office from as many Moose Lodges within the Moose Legion jurisdiction as possible.

3. Insure that no more than two (2) annually elected directors from each lodge is represented on the Board of Directors Nominees should possess the desire to run for office, as well as leadership qualities, people skills and the willingness to contribute time and effort to the success of their Moose Legion. The committee may nominate more than one Moose Legionnaire for a particular office.

### **Report to the Membership** ( Code of Rules Chapter 11.3)

A written report listing the candidates by office shall be presented to the membership a minimum of thirty (30) days prior to the election. These names are placed upon the official Moose Legion ballot for those offices requiring use of paper ballot (versus voting sign of the Order). Petitions or nominations from the floor are prohibited.

### **Dissolution**

The Nominating Committee is not a standing committee. After the written report has been given to the Moose Legion, the Nominating Committee is automatically dissolved. Subsequent elections require the committee to meet again.

### **CAMPAIGNING** ( Code of Rules Chapter 11.4)

The printing, circulating or distribution of resolutions, letters, tickets, other written or printed materials, or through any electronic media by a Moose Legionnaire or anyone acting on his behalf, suggesting, recommending, opposing or containing the names of proposed candidates for office, is strictly prohibited. For any violation of this section, the offending member(s) may be suspended and, the election of such director(s) declared void with orders issued for a new election. Verbal campaigning is allowed.

### **ELIGIBILITY OF NOMINEES** (Code of Rules Chapter 11.7)

A Moose Legionnaire wishing to be considered for nomination shall submit his name in writing, designating the particular office he desires. The nomination is submitted to any

member of the committee prior to the scheduled Nominating Committee meeting. The Nominating Committee shall consider all names submitted and select from these names, or other names approved by the committee, at least one (1) candidate for the offices of President, Vice-President, Chaplain, Fraternal Director, and Financial Director respectively. However, certain requirements and qualifications are necessary for nomination to the office of President. (See paragraph under "qualifications")

**NOTE:** These requirements do not apply to a newly instituted Moose Legion.

## **DIRECTOR QUALIFICATIONS**

### **Board of Directors** ( Code of Rules Chapter 11.7)

A Moose Legionnaire must be in active status with his Lodge and must have at least six (6) months of active status Moose Legion membership in his Moose Legion, preceding May 1st of the year of his election. He must also have completed an authorized Moose Legion Educational Conference (MLEC) within three (3) years prior to assuming office. A member may only hold one (1) elected office in the Moose Legion at the same time.

A member who has been removed from office is not eligible to hold office again for a three (3) year period unless approved by written dispensation of the International Moose Legion Director. A member under suspension because of charges preferred against him is eligible as a candidate for election to office, but if found guilty of a charge affecting his membership, the office shall be declared vacant. Elected Directors shall not be eligible to serve more than two (2) consecutive terms in any one (1) office unless authorized by the International Moose Legion Director. A dispensation will only be granted in exceptional circumstances and for compelling reasons.

**President** ( Code of Rules Chapter 11.7)

A Moose Legionnaire must complete at least one (1) year in another elected office of the Moose Legion in which he seeks office, and complete an authorized Moose Legion Educational Conference (MLEC) within three (3) years prior to assuming office. This requirement may be waived by dispensation from the International Moose Legion Director. After completing his term(s) as President, a Moose Legionnaire is not eligible to serve in another elected office, except as specified in the Code of Rules.

**Election Committee** (Code of Rules Chapter 11.5)

The President shall appoint an Election Committee of three (3) active status Moose Legionnaires who are not members of the Board of Directors or candidates for elected office. The committee shall conduct the election, pass on all questions concerning the election, count the ballots and report to the Moose Legion the results of the election. Each member of the committee shall sign the report and the report shall be attached to the Moose Legion minutes. The Election Committee is responsible for security and at no time shall any ballots or the ballot box be left unattended by any member of the committee. The committee must keep a record of all ballots issued. Ballots shall be counted (not numbered) to verify the number of Moose Legionnaires voting with the number of ballots. The ballot box must be sealed and initialed by the committee, and shall remain in the possession of the Election Committee for a period of forty-eight (48) hours. If no written challenge is made to the election within forty-eight (48) hours, the ballots are destroyed. If a written challenge is made to a member of the Election Committee within forty-eight (48) hours of the closing of the election, the Election Committee shall impound the ballots pending final determination by the Election Committee, or by any appellate officer or tribunal. Challenges or complaints regarding the election must be

made to the Election Committee. A challenger must be allowed to witness the recount along with the committee.

**Installation of Directors** ( Code of Rules Chapter 11.8)

The elected Directors and appointed officers shall be installed at the Annual Celebration or at a special installation ceremony approved by the Board of Directors prior to May 1 each year. The Junior Past President (who served as such during the past year) shall be the installing officer of his Moose Legion. All duly elected, appointed and installed officers shall take office as of Midnight, April 30th of each year. If for any reason the Junior Past President cannot act, the President-elect may appoint any Past President of the Moose Legion to conduct the installation ceremonies.

**Vacancies** ( Code of Rules Chapter 11.9)

If a vacancy occurs in any elective office other than President or Secretary, the office shall be filled by appointment of a qualified Moose Legionnaire by the Board of Directors. If a vacancy occurs in the office of President, the Vice- President shall assume the office as Acting President for the remainder of the term or until another Director is selected by the Board. If the vacancy occurs prior to November and the Acting President completes the term, he will be considered a Past Moose Legion President. Immediately upon a vacancy in the office of Secretary, the Board of Directors may appoint an Acting Secretary to serve for a period of time not to exceed six (6) months or until the next annual or special election, whichever shall first occur. The Financial Director shall serve as Acting Secretary on an interim basis until an Acting Secretary is appointed, but in no case for a period of time exceeding six (6) months. The International Moose Legion Director may declare any office vacant for a violation by the officeholder of the Code of Rules, General Laws or policies of Moose International, and appoint a qualified member of the Moose Legion to fill the vacancy created.

**Election of Directors**

The general election shall be held at a general membership meeting during the Annual Celebration scheduled between March 1 and April 30 of each year. Even if there is only one (1) candidate for each office, an election must be held. The election cannot be waived by a Moose Legion. Only active status Moose Legionnaires are eligible to vote during the election of the Board of Directors.

**Voting By Ballot** (Code of Rules Chapter 11.6)

The election should be the first order of business after the roll call of Directors and appointed officers. A late arriving member may be allowed to vote if the election is still in progress. The election must conclude in time for the Election Committee to count and tabulate the ballots and report results to the presiding officer. The results of the election may be announced as the last item of business before closing the meeting. A member may only vote for one (1) candidate for each office. Balloting shall be conducted in conformity with the Moose Legion Code of Rules and General Laws of the Order. A paper ballot must be prepared for each office having two (2) or more nominees. The Secretary shall prepare official ballots listing all names submitted by the Nominating Committee. The candidate for each office receiving a majority (two (2) or less candidates) or a plurality (three (3) or more candidates) of "yes" votes cast shall be declared elected. No absentee ballot, proxy vote or Australian Ballot shall be allowed.

**By Sign of the Order** ( Code of Rules Chapter 11.6)

If there is only one (1) candidate for each office, the Moose Legion may dispense with the paper ballot and conduct the election by using the voting sign of the Moose Legion. This must be decided just prior to the election. If approved, this method must be used for all uncontested offices.

After the report of the Nominating Committee, the presiding officer calls for a motion to adopt the



recommendation of the Nominating Committee and to elect those uncontested nominees for the offices specified. After receiving a motion and second, the presiding officer will ask all in favor to raise their hands and then ask all those opposed to raise their hands. Should those 'opposed' prevail, the election must proceed by paper ballot. However, it is permissible to conduct an election by paper ballot for each nominee. Any uncontested nominee receiving one (1) 'yes' vote is automatically elected. 'No' votes are not counted.

## Sample Ballot

### Election of Moose Legion Directors

\_\_\_\_\_Moose Legion No. \_\_\_\_\_

#### **President** - (Vote for One)

Joel (Joe) Nelson

#### **Vice - President** - (Vote for One)

Thomas (Tom) Aldi

Jim McArdle

Warren Grady

#### **Chaplain** - (Vote for One)

Ed Andersen

Robert (Bobby) Mitchell

#### **Financial Director** - (Vote for One)

Bob Smith

#### **Fraternal Director** - (Vote for One)

James (Jimmy) Jones

Hugh (Buddy) Brown

**QUESTIONS AND ANSWERS**

1. Does the Moose Legion have the right to nominate and elect officers without following the nominating procedure?  
**A. No.**
2. Must the Nominating Committee confine its recommendations to the names submitted to it?  
**A. No. The Nominating Committee shall select at least one (1) candidate for each office to be filled from the names submitted or it may reject any names and make other nominations.**
3. Just because a member's name is considered during the Nominating Committee meeting, is the name automatically placed on the ballot as a candidate?  
**A. No. The Nominating Committee must consider the qualifications, ability and willingness to serve of each suggested nominee. (See answer to question 2.)**
4. Do the terms of all the elected Directors expire each year?  
**A. Yes, except for the secretary.**
5. After a candidate is nominated, can he verbally solicit support by asking other members to support him at election time?  
**A. Yes. However there can be no printed or written materials circulated (i.e., letters, tickets, resolutions, sample ballots, etc.). Campaigning by electronic media is also prohibited. Verbally asking a member for his support is not prohibited.**
6. In the nomination and election of Directors, can names be placed on the ballot without designating the specific office?  
**A. No. A nominee must designate which office he desires when submitting his written nomination form.**

- 
7. May blank space be provided on a ballot so that names may be inserted at the election?
    - A. **No. The ballot shall carry only names of those nominated by the Nominating Committee. Petitions and nominations from the floor are prohibited.**
  
  8. What is juniority of a Past President?
    - A. **Juniority means the order in which he most recently acquired title by service. Honorary Past Presidents are not included in the juniority list.**
  
  9. May a Past President be a candidate for elected director?
    - A. **Yes. The Past President must be running for his second consecutive one (1) year term as President. Otherwise, to be eligible for the office of President, he must again serve one year in another elected office and meet all other qualifications required by the Code of Rules.**
  
  10. Can a member be eligible for election to more than one (1) directorship in the Moose Legion at the same time?
    - A. **No.**
  
  11. Who are eligible as candidates for the offices of Financial Director, Fraternal Director, Chaplain, and Vice-President?
    - A. **Any member who is in active status in his Lodge and Moose Legion, has completed six (6) months of Moose Legion membership and has completed an authorized Moose Legion Educational Conference (MLEC) within three (3) years prior to assuming office.**
  
  12. May a Moose Legion hold its general election of Directors at any time it may determine?

- A. No. The Code of Rules provides that Directors shall be elected at the Annual Celebration between March 1 and April 30 each year.**
13. By what authority may the Australian ballot be used?  
**A. The Australian Ballot is prohibited in the Moose Legion.**
14. Is a Moose Legionnaire whose membership card expires March 31st eligible to vote in the general election?  
**A. Yes, if the Annual Celebration is held between March 1st and March 31st. Should the Celebration be held in April, the Moose Legionnaire must show a paid up membership card, or the Moose Legion Secretary must verify that his dues are current.**
15. Is a member whose membership card has expired eligible to vote in a special election?  
**A. No.**
16. In voting, what constitutes (a) a majority (2 or less candidates) and (b) a plurality (3 or more candidates)?  
**A. A majority or plurality is when a candidate receives more "yes" votes than any other candidate for the same office.**
17. When should officers be installed?  
**A. At the Annual Celebration or at a special installation ceremony approved by the Board of Directors prior to May 1 each year. New terms begin May 1st.**
18. How many annually elected Directors are allowed from the same Lodge?  
**A. Only two (2) annually elected members of the Board of Directors is allowed from each Lodge in the jurisdiction during the same term (providing the Moose Legion has at least three**

**(3) Lodges) unless authorized by the Director of the International Moose Legion.**

19. Who represents the Moose Legion as a representative at the Annual International Moose Legion Conference and Ritual Competition?
- A. The President and Secretary are the official representatives. However, any active status member selected by the Moose Legion membership may serve as a representative, delegate or alternate.**
20. Should a sample ballot be printed in the Moose Legion publication immediately following the report of the Nominating Committee?
- A. Yes.**
21. Can a candidate have the name he is known by used on the ballot in lieu of his given name?
- A. Yes.**
22. The Financial Director was appointed by the Board of Directors in January and approved by the membership at the following regular/general membership meeting. Does the office of Financial Director have to be declared open in the upcoming general election to be held at the Annual Celebration?
- A. Yes. The Code of Rules states that the appointment is effective only until the next general election.**
23. Is the Moose Legion required to post or publish the meetings and schedule of events for the Nominating Committee and general elections?
- A. No. It is only required that the Nominating Committee provide the membership with a written slate of Directors and give a verbal report at the Annual Celebration. Although it is not necessary, there is nothing that prohibits posting or publishing this information (sample on next page).**

**NOMINATING/GENERAL ELECTION NOTICE**

**March 2nd**      **Nominating Committee meets (time and place). Moose Legionnaires must submit name, in writing and prior to the meeting, to a member of the Nominating Committee in order to be considered for nomination.**

**March 10th**    **Slate of Candidates mailed to all members.**

**April 15th**    **Election at (time and place) during Annual Celebration**

24. Is there a suggested format to be used when submitting one's name to a Nominating Committee for their consideration?

**A. Yes, (example follows)**

(Suggested format for submitting name for consideration of the Nominating Committee)

I, Moose Legionnaire \_\_\_\_\_  
(first, middle (and/or nickname) and last name)

MID \_\_\_\_\_

of \_\_\_\_\_ Lodge No. \_\_\_\_\_

wish to be considered for the office of \_\_\_\_\_.  
(state title of office)

I recognize the responsibilities and duties of this office and

I am willing to devote the necessary time and effort required by this office if elected.

---

Signature

---

Date

25. May the President vote at the election of Directors?

**A. Yes, the same as any other active status Moose Legionnaire.**

## **RESPONSIBILITIES OF DIRECTORS**

The Nominating Committee should familiarize itself with the various duties and responsibilities of each elected Director in order to convey this information to prospective candidates. A condensed version of each elected Director's responsibilities is listed on the following pages (complete details of all seven (7) members of the Board of Directors duties are in the Code of Rules).

It is recommended a copy of Directors' responsibilities be distributed to those expressing an interest in running for an elected Director's position.

### **PRESIDENT**

The President shall preside at all meetings of the Moose Legion. The President shall decide all parliamentary questions which may arise in the Moose Legion subject to appeal. In addition to the Secretary, he shall be one of two official representatives to the Annual Moose Legion Conferral Competition and Conference. The President shall appoint a Sergeant-at-Arms and Assistants as needed, who shall serve at the pleasure of the President. The President shall appoint the chairman of all committees as required. The President and the Junior Past President shall count all votes cast except election ballots. The President shall cast the deciding vote upon all questions as provided by Roberts'

Rules of Order, except in the election of Directors and alternate representatives.

The President shall, with the Secretary and Financial Director, be responsible for the safekeeping of all securities and valuable papers. He is authorized to sign all approved checks. At least two (2) signatures are required on each check; one shall be that of the Secretary and the other shall be that of the President or Financial Director. The President shall also sign all other documents requiring his signature. He shall see that all funds of the Moose Legion are deposited in the bank by the Secretary in the name of the Moose Legion, and that a certified deposit slip is given the Financial Director for every deposit. He shall periodically examine all books, records and documents of all officers of the Moose Legion for the protection of the funds of the Moose Legion. He may call for a special audit, if determined necessary by the Board of Directors. He shall perform all other duties required of him by the Code of Rules and Conferral of the International Moose Legion.

He shall have responsibility for an active Moose Legion Committee in each lodge within the jurisdiction and shall ensure that each Lodge Moose Legion Committee is attended at least once by either himself or a member of the Board of Directors during his term in office.

He will have the sole responsibility of delegating which Lodge Moose Legion Committee meetings are attended by himself or another member of the Board of Directors as established during a planning meeting by the Board of Directors.

He shall properly complete and compile each Lodge visitation report on his own visitation or visitations by a member of the Board of Directors that have been forwarded to him and send the report to the International Moose Legion Ambassador on the form required by the International Moose Legion.



Upon receipt of court documents, a certificate from the clerk of any court or other satisfactory proof that a member has been convicted of a felony, he shall order the member expelled from membership in the Moose Legion, unless the member has received a special dispensation from the General Governor allowing him to retain his membership in the Order.

If a vacancy occurs in the office of President, the Vice-President shall become the Acting President. He shall perform the duties and responsibilities related to this office until a new President is elected or appointed.

The President's goals should be to increase active membership, increase new members and increase finances during his term.

### **VICE-PRESIDENT**

He is a member of the Board of Directors. He presides in the absence of the President, assists the President in preserving order and decorum and performs all other duties required of him by the Code of Rules and Conferral of the International Moose Legion. He is Chairman of the Membership Building Committee. He selects the members of the committee who shall be responsible for membership promotion and quarterly membership campaigns. The goal of this committee is to increase the members on the rolls.

If a vacancy occurs in the office of President, he shall assume the office in an acting capacity, with full authority to perform the duties and the responsibilities of the President.

### **CHAPLAIN**

He is a member of the Board of Directors. He shall perform all duties required of him by the Code of Rules and Conferral of the International Moose Legion.

The Chaplain is Chairman of the Publicity and Member Relations Committee and selects the committee members. The committee is responsible for advertisement, publicity and communications with the membership on a quarterly basis. The committee is also responsible for 'Fun and Frolic', which is the planning and execution of activities and entertainment and to encourage active participation of all Moose Legionnaires and their families at Celebrations. The committee goals are to increase Moose Legion awareness and increase attendance at Celebrations.

He shall contact the sick, disabled and distressed and make a full report to the Moose Legion at each meeting.

The Chaplain shall deliver all prayers as required.

The Chaplain is a member of the Audit Committee, but shall not serve as its Chairman.

### **FRATERNAL DIRECTOR**

He is a member of the Board of Directors. In the absence of the President and Vice-President, he shall preside at all meetings of the Moose Legion. He shall perform all duties required of him by the Code of Rules and Conferral of the International Moose Legion.

He is Chairman of the Fraternal Operations Committee and selects the members of this committee. The committee is responsible for collecting the Mooseheart/Moosehaven Endowment Fund at all meetings and performing the Legacy of the Moose or Golden Ball Ceremony on an annual basis. The committee's goal is to increase Endowment Fund donations over the previous year.

He and the Financial Director shall examine all bills, except recurrent overhead items, and report to the Board of Directors their recommendations as to payment.

The Conferral of the Moose Legion is under the direction

of the Fraternal Director. He shall ensure the principles, goals and ideals of the Degree of Service are exemplified in Conferrals prepared and approved by the International Moose Legion Council. These Conferrals shall be used in various ceremonies and the enrollment of members into the Moose Legion. He, along with the Conferral team, shall raise funds for International Competition.

### **FINANCIAL DIRECTOR**

He is a member of the Board of Directors. He shall perform all duties required of him by the Code of Rules and Conferral of the International Moose Legion.

The Financial Director, Secretary and President shall be responsible for the safekeeping of all securities and valuable papers. He shall receive a duplicate deposit slip from the Secretary showing all funds deposited and credited to the Moose Legion. He shall initial the duplicate deposit slip retained by the Secretary.

The Financial Director is authorized to sign all approved checks. At least two (2) signatures are required on each check; one shall be that of the Secretary and the other shall be that of the President or Financial Director.

He and the Fraternal Director shall examine all bills, except recurrent overhead items, and report to the Board of Directors their recommendations as to payment.

The Financial Director is Chairman of the Fund Raising Committee. He selects the committee members who will be responsible for raising funds for Mooseheart, Moosehaven, Camp Ross and other various projects designated during his term. The committee's goal is to increase the assets of the Moose Legion.

The Financial Director shall collect and classify all funds,

except fees and dues, received during a Celebration or meeting, deliver all funds to the Secretary at the conclusion of the meeting and obtain a receipt for all funds collected. A receipt shall be retained with his records.

If a vacancy in the office of Secretary occurs, the Financial Director shall serve as temporary Secretary, unless another is appointed.

## **CONCLUSION**

We hope this handbook will answer many of the questions you have regarding the election process. However, if you still have a question or need clarification about the procedures involved you should:

Review the Code of Rules and this handbook to clarify the point of issue in question.

After studying the Code of Rules, if you are still unsure or unclear on the point or issue, talk with other experienced members (i.e. Past Presidents, Secretary), your International Moose Legion Ambassador, Moose Legion Area Manager, or a Member of the International Moose Legion Council.

After exhausting the above, and if time allows, submit your question in writing to the International Moose Legion Director for clarification. If time is of the essence, call the International Moose Legion Office for assistance at (630) 966-2260. Written questions may be faxed to (630) 966-2208.

*Installation Ceremonies for*  
**MOOSE LEGION**

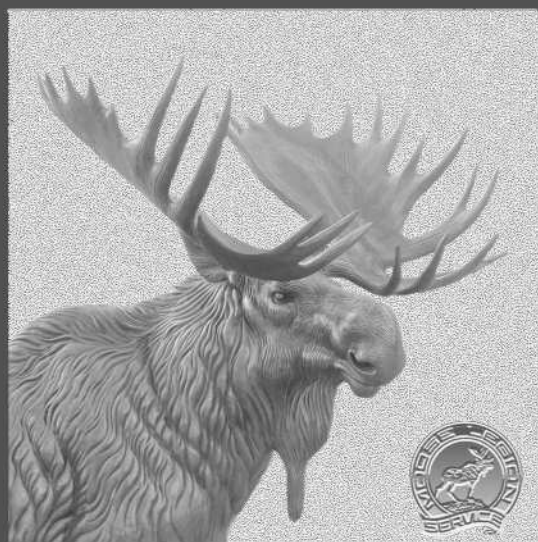

**ELECTED DIRECTORS**  
**AND**  
**APPOINTED OFFICERS**

*The Moose Legion is  
known as the*  
**DEGREE OF SERVICE**

*OUR MISSION. . .*

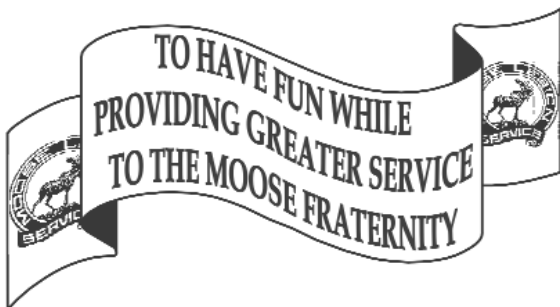

*OUR VISION. . .*

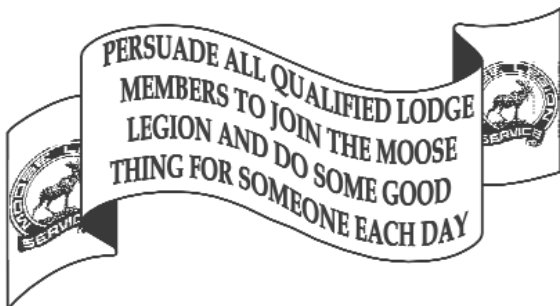

---

## INSTALLATION CEREMONIES

For Moose Legion Directors and Appointed Officers Attendance at installation of Moose Legion Director ceremonies is limited to Moose Legionnaires and their ladies. However, family members and honored members of the community may, in accordance with the General Laws, attend at the discretion of the Board of Directors and the host Lodge.

At the institution of a new Moose Legion, it is recommended that family members and honored members of the community be invited to attend the installation of officers.

The meeting room must be set as described in the Moose Legion Conferral and the meeting opened in the normal fashion.

Chairs are arranged behind the Altar as outlined in Diagram No. 4 . During special installation ceremonies, no other business need come before the membership.

The Jr. Past President (who served as such during the past year) shall be the installing officer of his Moose Legion. An Installing Sergeant-at-Arms, selected from the ranks of active Moose Legionnaires, shall be appointed by the Installing Officer to assist with the Installation Ceremony. All duly elected directors shall be installed at the Annual Celebration each year, or at a special Installation Ceremony approved by the Moose Legion Board of Directors to be held prior to April 30. The new Board of Directors takes office as of Midnight April 30. If, for any reason, the Junior Past President does not act, the President elect may appoint any Past North Moose or Past President of the Moose Legion to conduct the Installation Ceremony. In midterm, a Director-appointed shall be installed by the Installing Officer, who shall use only such portions of the ceremony pertaining to such Director-appointed.

Before the ceremony begins, the Installing Officer should provide a copy of the prayer to the Chaplain (elect). Copies of this prayer can be found in the back of this book.

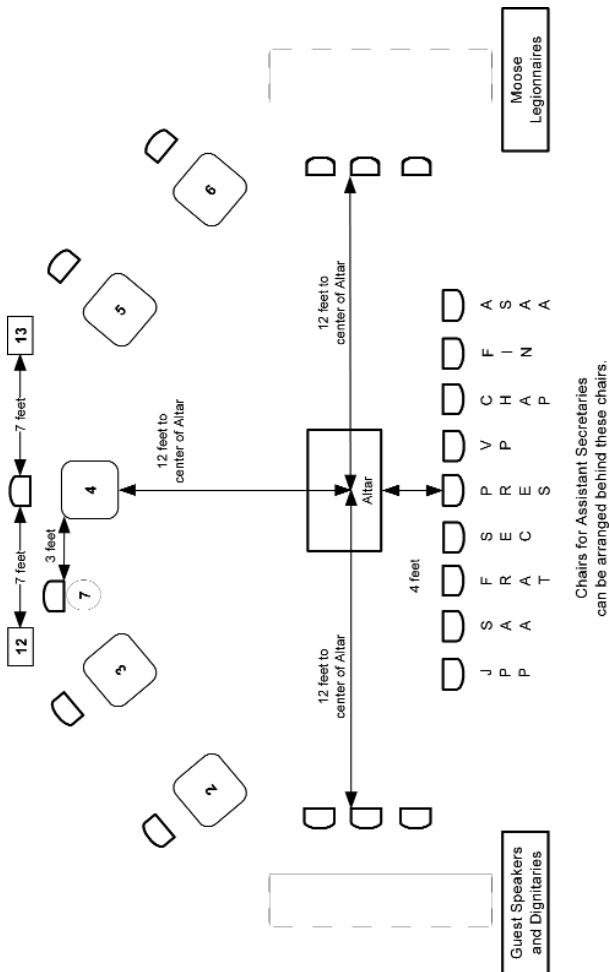

Diagram No. 4



## INSTALLATION CEREMONY

**PRESIDENT:** *(Gives one rap.)* Moose Legionnaires and guests, welcome to the installation of your newly elected Directors and appointed officers. I have the honor of introducing Past President (Past North Moose) \_\_\_\_\_ who will be our Installing Officer.

**PRESIDENT:** *(Gives two raps)* Everyone will rise.

**PRESIDENT:** Installing Officer \_\_\_\_\_, I hand you the gavel as a symbol of your authority.

**INSTALLING OFFICER:** *(Gives one rap)* Everyone will be seated.

*(The President takes a seat at the right of the Installing Officer.)*

**INSTALLING OFFICER:** Moose Legionnaires, I am here for the purpose of installing your elected Directors and appointed officers. Before doing so, it is my duty to ascertain whether your retiring officers have complied with the Moose Legion Code of Rules and the General Laws of the Order.

Brother President, have the Moose Legionnaires whom \_\_\_\_\_ Moose Legion No. \_\_\_\_\_ desires to install into office for the current year been elected or appointed in strict compliance with the Moose Legion Code of Rules and the General Laws of the Order?

**PRESIDENT:** They have.

**INSTALLING OFFICER:** Will the retiring officers please rise? Please join me in applauding the time, effort and faithful service these Moose Legionnaires have rendered to the Degree of Service and to the Order during the preceding year. Thank you for a job well done! *(Pause)* The retiring officers will please vacate their stations. *(Retiring officers vacate stations.)*

**INSTALLING OFFICER:** The Secretary will call the roll of the directors-elected and officers appointed. As each name is announced, he will report to the Installing Sergeant-At-Arms at the Altar and be seated as instructed. *(The officers elected and appointed shall be seated at the Altar, as shown in the diagram on page 2.)*

**INSTALLING OFFICER:** Moose Legionnaires, do any of you have just cause to show why any or all of the elected directors or appointed officers for this Moose Legion should not be installed into office? If so, please make it known at this time.

*(If any cause should be presented which cannot be satisfactorily adjusted, the Installing Officer shall require the elected director or appointed officer to retire from his position at the Altar. He shall then proceed to install the remaining officers. Immediately following the installation, the Board of Directors shall submit a detailed report covering the cause for deferring installation to the International Moose Legion Director and await his decision. Pending a decision of the Director, the officer who held such office at the close of the preceding term shall fill the office for which installation was deferred. If he is not available, appointment shall be made by the Installing Officer.)*

**INSTALLING OFFICER:** Since there appears to be no objection to any of the officers, we will proceed with the Installation Ceremony.

**INSTALLING OFFICER:** *(Addressing officers elected and appointed)* Do each of you accept the office to which you have been elected or appointed? If so, answer I do.

**OFFICERS-ELECT:** I do.

**INSTALLING OFFICER:** Elected directors and appointed officers will rise. Place your left hand over your heart, raise your right hand, and repeat after me, using your

name where I use mine. I, \_\_\_\_\_,  
 — do solemnly promise — that I will faithfully — and to  
 the best of my ability — perform the duties of the office —  
 to which I have been elected or appointed. — I will  
 comply with the Moose Legion Code of Rules — and the  
 General Laws of this Order. — I will memorize the portion  
 of the Conferral — pertaining to the office I hold. — I will  
 obey all orders — emanating from the International Moose  
 Legion Council, — the officers of the Supreme Lodge —  
 and Moose International. — I will endeavor to fulfill —  
 our Mission to have fun, — while providing greater  
 service to the Moose Fraternity. — I will, by word and  
 action, — do some good thing for someone each day. — I  
 will promote membership in the Degree of Service — by  
 inviting all qualified Moose members — to join the Moose  
 Legion. — I will promote and support all Moose Legion  
 programs, — and I will strive to reach — the level of  
 Moose service — that merits advancement to — the  
 Fellowship and Pilgrim Degrees. — I will help lead my  
 Moose Legion — toward membership and financial  
 progress. — I will deliver to my successor in office, — or  
 to any other legal authority of the Order, — all funds and  
 property in my possession — belonging to this Moose  
 Legion — or to any other unit of the Order. — I further  
 promise — that I will set a positive example — for all  
 Moose Legionnaires to follow. — By this obligation, I  
 pledge my leadership. You may be seated.

**INSTALLING OFFICER:** Installing Sergeant-at-Arms,  
 present the out-going President at this station. (*Installing  
 Sergeant-at-Arms does as directed.*)

**INSTALLING OFFICER:** Moose Legionnaire \_\_\_\_\_,  
 you have served this Moose Legion faithfully as the  
 presiding officer. (For new Moose Legion institutions -  
 Moose Legionnaire \_\_\_\_\_, you have been  
 appointed as the Junior Past President of this Moose

Legion.) You are qualified to act as an advisor on matters upon which you will be called to speak, and your attendance at Moose Legion meetings will assure that the good accomplished under your leadership will continue.

As the Junior Past President, you will continue as a member of the Board of Directors and perform all duties required by the Moose Legion Code of Rules and Conferral. You are the Chairman of the Membership Retention Committee with responsibility to increase the active membership of this Moose Legion.

You will assist the President in inspecting all ballots on applicants, and you are the Installing Officer of this Moose Legion until another has taken your place. As a Past President, you are now entitled to enjoy all the rights and privileges associated with this honor.

I now declare you duly installed as the Junior Past President of this Moose Legion and invest you with the emblem of your office. Installing Sergeant-at-Arms, please escort the Junior Past President to the station of Loyalty.

**INSTALLING OFFICER:** The Moose Legion Secretary will call the roll of his appointments as Assistant Secretaries for the Lodges in this Moose Legion jurisdiction. Please stand as your name is called and remain standing until otherwise instructed.

*(Secretary Calls roll.)*

Your appointment is vital to the well being of this Moose Legion. You are the Secretary of your Lodge Moose Legion Committee and will accurately maintain the minutes, keep accurate financial records, read correspondence and be the center for communications with all Moose Legionnaires in your Lodge. You shall be responsible to the Moose Legion Secretary, promote all programs of the Moose Legion, and

assist in the building and retention of the membership of this Moose Legion. You are a voting member of the Nominating Committee responsible for selecting the future leadership of this Moose Legion. Your dedication and efforts will make a difference in the success of your Lodge Moose Legion Committee and this Moose Legion. Thank you for accepting this vital appointment. Please be seated.

**INSTALLING OFFICER:** Installing Sergeant-at-Arms, present the Assistant Sergeant-at-Arms at this station (*more than one is permitted*).  
(*Installing Sergeant-at-Arms does as directed.*)

**INSTALLING OFFICER:** Moose Legionnaire(s) \_\_\_\_\_, you shall assist the Sergeant-at-Arms with the ceremonies of the Moose Legion and perform such other duties as required by the President. You will acquaint yourself with the Conferral and the duties of the Sergeant-at-Arms and be prepared to perform such duties in his absence. I now invest you with the emblem(s) of your office and declare you duly installed. Installing Sergeant-at-Arms, please escort the Assistant Sergeant-at-Arms to his/their chair(s).

**INSTALLING OFFICER:** Installing Sergeant-at-Arms, present the Sergeant-at-Arms at this station. (*Installing Sergeant-at-Arms does as directed.*)

**INSTALLING OFFICER:** Moose Legionnaire \_\_\_\_\_, you are under the direction of the President. You shall assist members, visitors, or latecomers in making proper entry into the meeting room. You are in charge of the property and paraphernalia of the Moose Legion not otherwise provided for. You shall properly arrange the room for all meetings and special functions, and immediately remove the paraphernalia after every meeting.

You shall perform such other duties as may be designated by the Moose Legion Conferral or required by the

President. I now invest you with the emblem of your office and declare you duly installed as Sergeant-at-Arms. Installing Sergeant-at-Arms, please escort the Sergeant-at-Arms to his chair.

**INSTALLING OFFICER:** Installing Sergeant-at-Arms, present the Fraternal Director-elect at this station. *(Installing Sergeant-at-Arms does as directed.)*

**INSTALLING OFFICE:** Moose Legionnaire \_\_\_\_\_, you are the Chairman of the Fraternal Operations Committee, which is responsible for collecting the Mooseheart/ Moosehaven Endowment Fund at all meetings and performing the Legacy of the Moose or Golden Ball Ceremony on an annual basis. The Conferral of the Moose Legion is also under your direction. You shall ensure the principles, goals and ideals of the Degree of Service are exemplified in approved Conferrals performed in various ceremonies and the enrollment of new Moose Legionnaires.

You and the Financial Director shall examine all bills and report to the Board of Directors your recommendation as to payment. As a member of the Board, you shall perform all other duties required of you by the Moose Legion Code of Rules and Conferral. Fraternalism is the heart and soul of the Degree of Service. Your challenge is to build the spirit of fraternalism to new heights within this Moose Legion. I now present you with the emblem of your office and declare you duly installed as Fraternal Director. Installing Sergeant-at-Arms, please escort the Fraternal Director to the station of Charity.

**INSTALLING OFFICER:** Installing Sergeant-at-Arms, present the Financial Director-elect at this station. *(Installing Sergeant-at-Arms does as directed.)*

**INSTALLING OFFICER:** Moose Legionnaire \_\_\_\_\_, along with the Secretary and President, you shall be

responsible for the safekeeping of all securities and valuable papers. You and the Fraternal Director shall examine all bills and make recommendation to the Board of Directors as to payment.

You are the Financial Director of this Moose Legion Corporation and authorized to sign all checks as ordered paid by the Moose Legion. You shall receive from the Secretary all deposit slips showing deposits made by him in financial institutions in the name of the Moose Legion and report this information to the membership at regular meetings.

You are also the Chairman of the Fundraising Committee and shall collect and classify all funds during Celebrations and meetings. You are responsible for raising funds for Mooseheart, Moosehaven, and Camp Ross projects, and increasing the assets of this Moose Legion. You can assure the confidence the members have placed in you by exercising the utmost care and fidelity in performing your duties as required by the Moose Legion Code of Rules and Conferral. I now invest you with the emblem of your office and declare you duly installed as Financial Director. Installing Sergeant-at-Arms, please escort the Financial Director to his desk.

**(IF THE SECRETARY HAS NOT BEEN PREVIOUSLY INSTALLED.)**

**INSTALLING OFFICER:** Installing Sergeant-at-Arms, present the Secretary at this station. (*Installing Sergeant-at-Arms does as directed.*)

**INSTALLING OFFICER:** Moose Legionnaire \_\_\_\_\_, you are the Secretary of this Moose Legion Corporation and, along with the Financial Director and President, are a custodian for the securities and valuable papers. You shall correctly keep minutes of all meetings of this Moose Legion, maintain accurate membership and financial

reports, preserve and file all valuable papers, report all membership records as required, sign all approved checks and legal documents, and read all correspondence to the Board of Directors and Moose Legion membership. As Secretary, you shall appoint an Assistant Secretary in each Lodge within this Moose Legion Jurisdiction.

You shall make timely Financial Reports to Moose International, and perform all other duties as required by the Moose Legion Code of Rules and Conferral. You shall carefully study all the rules of the Moose Legion, insist your books be audited regularly by the local auditing committee, and be zealous in your efforts to keep this Moose Legion in active status in the International Moose Legion, so the members may be entitled to all the benefits provided.

As correspondent for the Moose Legion, your promptness in communicating with the Moose Legion membership and Moose International is of vital importance. Believing your ability and zeal in the discharge of your duties will contribute to the success and prosperity of this Moose Legion, I present you with the emblem of your office and declare you duly installed as Secretary.

Installing Sergeant-at-Arms, please escort the Secretary to his desk.

**INSTALLING OFFICER:** Installing Sergeant-at-Arms, present the Chaplain-elect at this station. (*Installing Sergeant-at-Arms does as directed.*)

**INSTALLING OFFICER:** Moose Legionnaire \_\_\_\_\_, you are the Chairman of the Publicity and Member Relations Committee with responsibility for advertisement, publicity and communications with the membership. This committee also has the duty of planning and executing activities and entertainment to encourage greater participation at Celebrations.



You are a member of the Auditing Committee, and shall perform all other duties as required by the Moose Legion Code of Rules and Conferral. It will be your duty to promptly contact or visit the sick and be as helpful as possible to the needy and distressed. As yours is the station of Faith, you shall invoke the blessing of the Supreme Being in our services and ceremonies. Let your conduct and demeanor be an example for all Moose Legionnaires to follow. I now present you with the emblem of your office and declare you duly installed as Chaplain. Installing Sergeant-at Arms, please escort the Chaplain to the station of Faith.

**INSTALLING OFFICER:** Installing Sergeant-at-Arms, present the Vice-President-elect at this station. (*Installing Sergeant-at-Arms does as directed.*)

**INSTALLING OFFICER:** Moose Legionnaire \_\_\_\_\_, you are Vice-President of the Moose Legion Corporation, a member of the Board of Directors, and shall perform all duties required of you by the Moose Legion Code of Rules and Conferral. You will assist the President in preserving order and decorum in the Moose Legion and in the absence of the President, preside over the deliberations of this Moose Legion with full authority to perform his duties and responsibilities.

You are the Chairman of the Membership Building Committee and responsible for membership promotion and quarterly membership campaigns. I now invest you with the emblem of your office and declare you duly installed as Vice-President. Installing Sergeant-at-Arms, please escort the Vice-President to the station of Hope.

**INSTALLING OFFICER:** Installing Sergeant-at-Arms, present the President-elect at this station. (*Installing Sergeant-at-Arms does as directed.*)

**INSTALLING OFFICER:** Moose Legionnaire \_\_\_\_\_, I welcome you to the station of leadership. You are the President of the Moose Legion Corporation and the Board of Directors. You shall preside at all meetings of the Moose Legion, preserve order, apply and enforce all the rules of the Moose Legion and decide parliamentary questions.

You, along with the Secretary and Financial Director, are a custodian of all securities and authorized to sign all approved checks. You are a member of all prescribed standing committees of the Moose Legion and will assist the Junior Past President in counting all votes cast except election ballots.

The President and the Secretary are the two official representatives to the Annual International Moose Legion Conferral Competition and Conference. While you are President, this Moose Legion should show an increase in active membership and an increase in net assets.

Your main responsibility is to visit each Lodge in this Moose Legion jurisdiction, ensuring the Lodge Moose Legion Committee is active and functioning for the enjoyment of the Moose Legionnaires and their families, and of service to the Lodge. A report of your visitation must be properly reported to the International Moose Legion Ambassador.

Listen with respect to the opinion of other Moose Legionnaires, and in making decisions, remember that your own feelings or interests must have no weight. The Moose Legion membership should be harmonious, diligently promoting our purposes, and enthusiastically engaged in furthering our fraternal objectives.

Upon completion of your term of office, you become a Past President of this Moose Legion and entitled to enjoy all rights and privileges associated with this honor. The members of this Moose Legion now confer a distinctive honor upon you and it is my pleasure to invest you with the

emblem of your office. I declare you duly installed as President of this Moose Legion. Installing Sergeant-at-Arms, please escort the President to a place on my left.  
*(President stands at left of Installing Officer.)*

**INSTALLING OFFICER:** Directors and appointed officers, the membership of this Moose Legion have placed their trust in your dedication, and ability to lead \_\_\_\_\_ Moose Legion No. \_\_\_\_\_ for the coming year. The welfare, progress and expectations of this Moose Legion, as well as the activities and participation of its members and their families, depend entirely on both your individual and collective actions.

I challenge each of you to seriously consider the principles and concept of the Degree of Service and the part you will play in its future. By the authority vested in me as Installing Officer, I now declare the Board of Directors and appointed officers of this Moose Legion duly installed.

**INSTALLING OFFICER:** *(Gives two raps.)* Everyone will rise. The Chaplain will ask the blessing of the Supreme Being.

**CHAPLAIN:** *(At Altar position 14)* Let us fold our arms and bow our heads. Supreme Being, we ask you to watch over these officers, to whom the leadership of this Moose Legion is committed. Implant in their hearts the spirit of Fraternal service; guide them in the principles of Faith, Hope, Charity and Loyalty; instill wisdom into their decision-making and lead them toward greater contributions to the humanitarian efforts of the Degree of Service. We especially ask for peace and harmony to prevail in this Moose Legion, and that prosperity and good health be granted to each individual member and his family. Give each of us the courage to live up to our pledge of doing some good thing for someone each day. We ask

these things in thy name. Amen.

**MEMBERS:** *(in concert) Amen (Chaplain returns to station)*

**INSTALLING OFFICER:** Moose Legion President \_\_\_\_\_, I hand you the gavel as a symbol of your authority. Wield it firmly, never in anger, and always with discretion.

**INSTALLING OFFICER:** Moose Legionnaires (ladies and guests), I have the pleasure of presenting your new Moose Legion President, the Board of Directors and appointed officers (applause).

**PRESIDENT:** *(Gives one rap.)* Everyone will be seated. *(Installing Officer takes a seat at the right of the President who proceeds with the regular order of business or with the program.)*

*(Proceed with regular order of business. See page 33 starting at "ENDOWMENT FUND").*

**CHAPLAIN:** (At Altar position 14) Let us fold our arms and bow our heads. Supreme Being, we ask you to watch over these officers, to whom the leadership of this Moose Legion is committed. Implant in their hearts the spirit of Fraternal service; guide them in the principles of Faith, Hope, Charity and Loyalty; instill wisdom into their decision-making and lead them toward greater contributions to the humanitarian efforts of the Degree of Service. We especially ask for peace and harmony to prevail in this Moose Legion, and that prosperity and good health be granted to each individual member and his family. Give each of us the courage to live up to our pledge of doing some good thing for someone each day. We ask these things in thy name. Amen.

-----

**CHAPLAIN:** (At Altar position 14) Let us fold our arms and bow our heads. Supreme Being, we ask you to watch over these officers, to whom the leadership of this Moose Legion is committed. Implant in their hearts the spirit of Fraternal service; guide them in the principles of Faith, Hope, Charity and Loyalty; instill wisdom into their decision-making and lead them toward greater contributions to the humanitarian efforts of the Degree of Service. We especially ask for peace and harmony to prevail in this Moose Legion, and that prosperity and good health be granted to each individual member and his family. Give each of us the courage to live up to our pledge of doing some good thing for someone each day. We ask these things in thy name. Amen.

-----

**CHAPLAIN:** (At Altar position 14) Let us fold our arms and bow our heads. Supreme Being, we ask you to watch over these officers, to whom the leadership of this Moose Legion is committed. Implant in their hearts the spirit of Fraternal service; guide them in the principles of Faith, Hope, Charity and Loyalty; instill wisdom into their decision-making and lead them toward greater contributions to the humanitarian efforts of the Degree of Service. We especially ask for peace and harmony to prevail in this Moose Legion, and that prosperity and good health be granted to each individual member and his family. Give each of us the courage to live up to our pledge of doing some good thing for someone each day. We ask these things in thy name. Amen.

**CHAPLAIN:** (At Altar position 14) Let us fold our arms and bow our heads. Supreme Being, we ask you to watch over these officers, to whom the leadership of this Moose Legion is committed. Implant in their hearts the spirit of Fraternal service; guide them in the principles of Faith, Hope, Charity and Loyalty; instill wisdom into their decision-making and lead them toward greater contributions to the humanitarian efforts of the Degree of Service. We especially ask for peace and harmony to prevail in this Moose Legion, and that prosperity and good health be granted to each individual member and his family. Give each of us the courage to live up to our pledge of doing some good thing for someone each day. We ask these things in thy name. Amen.

-----

**CHAPLAIN:** (At Altar position 14) Let us fold our arms and bow our heads. Supreme Being, we ask you to watch over these officers, to whom the leadership of this Moose Legion is committed. Implant in their hearts the spirit of Fraternal service; guide them in the principles of Faith, Hope, Charity and Loyalty; instill wisdom into their decision-making and lead them toward greater contributions to the humanitarian efforts of the Degree of Service. We especially ask for peace and harmony to prevail in this Moose Legion, and that prosperity and good health be granted to each individual member and his family. Give each of us the courage to live up to our pledge of doing some good thing for someone each day. We ask these things in thy name. Amen.

-----

**CHAPLAIN:** (At Altar position 14) Let us fold our arms and bow our heads. Supreme Being, we ask you to watch over these officers, to whom the leadership of this Moose Legion is committed. Implant in their hearts the spirit of Fraternal service; guide them in the principles of Faith, Hope, Charity and Loyalty; instill wisdom into their decision-making and lead them toward greater contributions to the humanitarian efforts of the Degree of Service. We especially ask for peace and harmony to prevail in this Moose Legion, and that prosperity and good health be granted to each individual member and his family. Give each of us the courage to live up to our pledge of doing some good thing for someone each day. We ask these things in thy name. Amen.

**CHAPLAIN:** (At Altar position 14) Let us fold our arms and bow our heads. Supreme Being, we ask you to watch over these officers, to whom the leadership of this Moose Legion is committed. Implant in their hearts the spirit of Fraternal service; guide them in the principles of Faith, Hope, Charity and Loyalty; instill wisdom into their decision-making and lead them toward greater contributions to the humanitarian efforts of the Degree of Service. We especially ask for peace and harmony to prevail in this Moose Legion, and that prosperity and good health be granted to each individual member and his family. Give each of us the courage to live up to our pledge of doing some good thing for someone each day. We ask these things in thy name. Amen.

-----

**CHAPLAIN:** (At Altar position 14) Let us fold our arms and bow our heads. Supreme Being, we ask you to watch over these officers, to whom the leadership of this Moose Legion is committed. Implant in their hearts the spirit of Fraternal service; guide them in the principles of Faith, Hope, Charity and Loyalty; instill wisdom into their decision-making and lead them toward greater contributions to the humanitarian efforts of the Degree of Service. We especially ask for peace and harmony to prevail in this Moose Legion, and that prosperity and good health be granted to each individual member and his family. Give each of us the courage to live up to our pledge of doing some good thing for someone each day. We ask these things in thy name. Amen.

-----

**CHAPLAIN:** (At Altar position 14) Let us fold our arms and bow our heads. Supreme Being, we ask you to watch over these officers, to whom the leadership of this Moose Legion is committed. Implant in their hearts the spirit of Fraternal service; guide them in the principles of Faith, Hope, Charity and Loyalty; instill wisdom into their decision-making and lead them toward greater contributions to the humanitarian efforts of the Degree of Service. We especially ask for peace and harmony to prevail in this Moose Legion, and that prosperity and good health be granted to each individual member and his family. Give each of us the courage to live up to our pledge of doing some good thing for someone each day. We ask these things in thy name. Amen.





Seconded by \_\_\_\_\_

Vote; Approved \_\_\_\_\_ Rejected \_\_\_\_\_

8. Communications & Notices
  - a. Official Communications
  - b. Notices from International Moose Legion
  - c. Notices from Association
  - d. Any miscellaneous notices
9. Sickness and Distress
10. Old Business
  - a. Current project Obligations
  - b. Progress of Lodge Committees
  - c. Quota Standings
11. New Business
  - a. New projects since last meeting
  - b. Next fund raiser event/ Next Celebration
  - c. Upcoming events Lodge Moose Legion Committee meetings
  - d. Other new business
12. Area Managers Report
13. Regional Managers Report
14. Adjourned

### **Secretary and Assistant Secretaries Meeting Agenda**

1. Welcome to this meeting of \_\_\_\_\_ Moose Legion # \_\_\_\_\_.
2. Introduction of Official Visitor or Invited Guest
3. Roll Call
4. Distribution of Reports;
  - a. Current Active Lodge Committee Roster
  - b. Current Lodge Committee Arrears List
  - c. Current List of Applications as excepted by LCL.net

(Review each List/Roster in detail and identify Lodge Moose Legion Committees that need improvement)

5. Review Lodge Moose Legion Committee Meetings. Discuss what is successful and what is not. Discuss what activities are being performed in conjunction with meetings.
6. Review/Discuss participation by Lodge Moose Legion Committees in jurisdiction fund raisers.
7. Comments from Ambassador, Area Manager or Official Visitor
8. General Discussion Session
9. Endowment Fund.
10. Adjournment